



DS10

(Hardware rev. 1.20 Firmware rev. 1.15)

Microstepping Stepper Motor Drive

User's Manual

The information in this document replace any other material previously published.

LAM Technologies reserves the right to change technical specification and price to any product here at any time and without further notice.

This manual contains reserved and proprietary information. All rights are reserved. It may not be copied, disclosed or used for any purposes not expressly authorized by LAM Technologies.

LAM Technologies warrants the products herein against defects in materials and workmanship for a period of 12 months. This warranty does not apply to defects resulting from an improper use, inadequate installation or maintenance. This warranty also does not apply in case the products are received modified or integrated with other parts and/or products not expressly authorized or provided for by LAM Technologies. This warranty also does not apply in case the product's label has been removed or modified.

Any assistance request must be addressed to the product's purchase source. In case of direct purchase from LAM Technologies a returned material authorization number (RMA) must be obtained from support@lamtechnologies.com clearly specifying the product code, the serial number, the problem found and the assistance required. The RMA will have to be clearly stated on each shipping documents otherwise the parcel could be rejected.

The customer shall be responsible for the packaging and shipping of the defective product to LAM Technologies and the shipment must be made charges prepaid. The product inspected, repaired or substituted will be available to be collected at LAM Technologies'.

During and within the warranty period, LAM Technologies can, on its judgment, repair or substitute the product. The cost of material and labor will not be charged within the warranty period.

The above warranty also does not apply to the software. LAM Technologies shall not be liable for any direct or indirect damages such as, but not limited to, costs of removal and installation, lost profits, coming from the use or the impossibility to use the software.

This manual is intended for skilled technical staff. In case the arguments, the terms and the concepts should not be clear you can contact support@lamtechnologies.com. It is forbidden to use the products herein described without being sure to have understood characteristics, installation and use procedures.

Even though products described have been designed with extreme care, they are not intended or authorized for use as components in applications intended to support or sustain life and in application in which the failure of the product could create a situation where injury or death may occur to people or animals.

LAM Technologies shall not be liable for any direct or indirect damages coming from the use of its products.

The information in this manual have been carefully checked and are believed to be accurate, however any suggestion to improve it will be highly appreciated.

LAM Technologies is a registered trade mark.

Contacts:

- *General information:* info@lamtechnologies.com
- *Technical support:* support@lamtechnologies.com
- *Commercial information:* sales@lamtechnologies.com

1	NOTES, TERMS AND WARNINGS	5
2	RISKS AND PRECAUTIONS	7
3	INTRODUCTION	9
3.1	PRODUCT DESCRIPTION.....	9
3.1.1	<i>Available models</i>	10
3.1.2	<i>Main Features</i>	10
3.2	ACCESSORIES	11
4	INSTALLATION	12
4.1	INSPECTION	12
4.2	MECHANICAL INSTALLATION	12
4.3	AIR COOLING	15
4.4	WIRING	17
4.4.1	<i>Power Supply: AC models</i>	19
4.4.2	<i>Power Supply: DC models</i>	24
4.4.3	<i>Motor</i>	31
4.4.4	<i>Control Signals</i>	33
4.4.4.1	<i>Inputs</i>	33
4.4.4.2	<i>Outputs</i>	36
4.4.5	<i>Chassis setting</i>	37
5	FUNCTIONALITY AND CONFIGURATION.....	39
5.1	GENERAL DESCRIPTION	39
5.2	SETTING	39
5.2.1	<i>Phase current</i>	39
5.2.2	<i>Automatic current reduction</i>	43
5.2.3	<i>Resolution</i>	45
5.2.4	<i>Current waveform modification</i>	46
5.2.5	<i>Inputs and outputs conditioning</i>	47
5.2.6	<i>Alarms and Protections conditioning</i>	49
5.3	INPUTS AND OUTPUTS	50
5.3.1	<i>General description</i>	50
5.3.2	<i>Inputs</i>	50
5.3.3	<i>Outputs</i>	52
5.3.4	<i>Timing relations among control signals</i>	53
5.4	SIGNAL LEDs.....	54
5.5	PROTECTIONS	56
5.5.1	<i>General description</i>	56
5.5.2	<i>Under voltage</i>	56
5.5.3	<i>Over voltage</i>	57
5.5.4	<i>Over temperature</i>	59
5.5.5	<i>Phase-to-phase short circuit</i>	60
5.5.6	<i>Phase-to-ground short circuit</i>	60
5.5.7	<i>Phase-to-V_p short circuit (Vac)</i>	60
5.5.8	<i>Interrupted phase A, interrupted phase B</i>	60
5.6	ADVANCED FUNCTIONALITIES.....	61
5.6.1	<i>General description</i>	61
5.6.2	<i>Gate</i>	61
5.6.2.1	<i>Configuration</i>	62
5.6.2.2	<i>Time relations among control signals</i>	63
5.6.3	<i>Oscillator</i>	64
5.6.3.1	<i>Configuration</i>	64
5.6.3.2	<i>Time relations among control signals</i>	66
6	TECHNICAL DATA.....	67

1 Notes, Terms and Warnings

In this manual some symbols, whose meaning is listed below, are used to underline particular arguments.



There is a dangerous condition which must be accurately evaluated and avoided. The not-respect of indications marked with this symbol can cause serious damages and injury to people, animals and things.

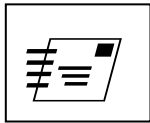

The subject is very wide and could require a deeper examination with the technical support.

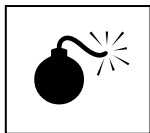

The non-observation of what described could damage the products.



Features and functionalities which cannot be easily found in other products. A shortcut to reach a target is shown.



A change or repairing intervention which can be made directly by the user.

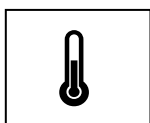

An aspect connected to the temperature or longevity of the product.

The terms listed below are also used:

Product

The microstepping drive described herein.

User

Who selects and/or installs and/or uses the product.





Application







The machine, the equipment, the device, etc. on which the product is applied.

2 Risks and Precautions

ATTENTION

Following are listed the most important warnings to be fully comprehended and applied by the user who, in case of non-complete comprehension or impossibility to apply them correctly, must not use the product at all.

	<p>The DS10 drives are components. It is the user's responsibility as the installer to be sure the product complies with the rules and regulations in force. The user must also be trained in the installation of the electronic equipment to fully comprehend the features, the calibration parameters and the indications contents of this guide.</p> <p>The user must provide for the application of all the local safety laws and regulations in force in the Country and/or application in which the product is used.</p>
	<p>The user must provide that the product is inaccessible while powered on. The user must also consider that, because of the capacitors inside the drive, it is necessary to wait at least for 30 seconds after the power off before acceding to the drive. According to the external capacitors eventually mounted on the power supply circuit, it is possible the user shall have to wait for a longer time.</p>
	<p>While working the product generates heat which can raise the temperature of some parts (as the heat sink, for example) up to values that can cause burns. Such a conditions remains for a long time even after the product has been powered off. The user must provide for the appropriate protections and signals, must train the operator, the technical support and risk maintenance staff, and then must indicate it in the service manual of the finished product.</p>
	<p>The high performance drive is able to generate rapid accelerations with high motor torque. Never touch any mechanical part while the drive is powered on. The user must prearrange the application in order this condition is always granted.</p>

	<p>The power supply of the product must be isolated from the electrical net. The user must always place a protective fuse in series to the power supply circuit.</p>
	<p>The control signals are isolated from the power supply during normal working; anyway, during the designing of the application, the eventuality that in case of breakdown these lines could reach the same potential as the power supply, must be considered to meet safety requirements.</p>
	<p>The product could be permanently damaged by corrosive substances (such as gas, salts, etc.), liquids or conductive dusts. Even a long and constant exposure to strong vibrations could cause the damage.</p>
	<p>During some damage conditions the drive could emit sparks and fire. The cabinet and the nearby components must be chosen to tolerate this eventuality and to avoid propagation of flames to the application.</p>
	<p>The products cannot be used in life support applications or where the failure of the products could cause death or injury to people, animals or things, or economic losses. The user not able to assure this condition must not use the products herein described.</p>
	<p>Do not dismantle the product, do not try and repair it and do not modify it without being expressly authorized by LAM Technologies.</p>
	<p>If the product is used in any manner that does not comply with the instructions given in this manual, then the product could be permanently damaged. For example, the product could be permanently damaged if power supplied with voltage superior to the allowed one, if supply polarity is inverted, if the motor is connected or disconnected while the drive is operating, and so on.</p>

3 Introduction

3.1 Product description

The DS10 High Performance Microstepping Drives are suitable for driving bipolar two phase stepping motors (at 4, 6 or 8 wires).



The current regulation is particularly cared and optimized and provides an accurate position and smoothness movement of the motor. The use of last generation power components, together with the development of an innovative control algorithm, has made possible to reach high levels of efficiency, compact size and reduced drive heating.



The high technology of the product has also allowed to overcome the previous full step or fractioned limited step solutions, offering at the same price a product able to drive in microstepping mode with an high step frequency.



Although the DS10 series is offered as a standard pulse train controllable drive, it includes an oscillator which allows to move the motor with a simple start/stop signal. Finally, the special functioning mode called *Gate* allows to control more drives through one only step source.



The DS10 drives series is equipped with a special port called DUP, designed for the setting and diagnostics of the drive. Through this device it is possible to intervene on many more parameters than the minimum ones allowed by the common dip switches, and to adapt at best the drive to the application. The bundled driver software guides the user in the product configuration simply and quickly, and it assists the user in the diagnostics giving in real time indication on the status of the drive, inputs, outputs, etc. Before starting to operate on the product, be sure to have the latest software version.

The use of last generation components and technologies, together with the computerized test made on each single unit, give to the product itself high reliability and economic competitiveness.

3.1.1 Available models

The DS10 family drives are available in a complete range of models diversified according to the power supply voltage and the phase current delivered by the motor. Many of them are also available in the AC supply version, identified by the letter A at the end of the code (for example DS1076A).

All the models shares the same functional features:

Model	AC power supply voltage (Vac)		DC power supply voltage (Vdc)		Effective phase current (Arms)		Peak phase current (A _{pk})	
	Min	Max	Min	Max	Min	Max	Min	Max
DS1041	---	---	18	50	0.3	1.4	0.42	2.0
DS1041A	16	36	---	---	0.3	1.4	0.42	2.0
DS1044	---	---	20	50	1	4	1.4	5.6
DS1044A	18	36	---	---	1	4	1.4	5.6
DS1048	---	---	20	50	3	8	4.2	11.3
DS1048A	18	36	---	---	3	8	4.2	11.3
DS1073	---	---	24	90	0.8	3	1.1	4.2
DS1073A	20	65	---	---	0.8	3	1.1	4.2
DS1076	---	---	24	90	2	6	2.8	8.5
DS1076A	20	65	---	---	2	6	2.8	8.5
DS1078	---	---	24	90	4	10	5.6	14.1
DS1078A	20	65	---	---	4	10	5.6	14.1
DS1084	---	---	45	160	2	4	2.8	5.6
DS1084A	35	115	---	---	2	4	2.8	5.6
DS1087	---	---	45	160	4	8,5	5.6	12.0
DS1087A	35	115	---	---	4	8,5	5.6	12.0
DS1098	---	---	45	240	4	10	5.6	14.1

3.1.2 Main Features

- ✓ Microstep resolution up to 25600 steps/rev in 14 different setting solutions
- ✓ Decimal and binary resolution
- ✓ STEP frequency over 300KHz
- ✓ Wide range of power supply
- ✓ AC power supply versions available
- ✓ Single supply voltage
- ✓ Current setting with increments of 0.1Arms
- ✓ Accurate current control
- ✓ Resonance damping
- ✓ High efficiency, low losses and contained heating
- ✓ Chopper frequency over 20KHz
- ✓ Automatic current reduction settable from 0% up to 100% with increments of 10%
- ✓ Current reduction time settable from 0.05 up to 10 seconds
- ✓ Optocoupled and differential inputs independently NPN or PNP usable
- ✓ Current reset on each input (no external limiting resistor is required)
- ✓ Wide inputs working range (from 3Vdc up to 28Vdc)

- ✓ Line driving supported
- ✓ ENABLE input to turn off the current to the motor
- ✓ BOOST input to dynamically modify the current to the motor
- ✓ Optocoupled and differential outputs independently NPN or PNP usable
- ✓ Protective diode for inductive loads
- ✓ Digital signal conditioning for each I/O
- ✓ Internal oscillator for a simple start/stop control of the motor
- ✓ *Gate* function to control more drives with one only pulse generator
- ✓ Efficient and complete diagnostics supported by a PC
- ✓ Over/under voltage protections
- ✓ Phase to phase short circuit protection both direct and crossed
- ✓ Phase to ground short circuit protection
- ✓ Positive supply short circuit protection
- ✓ Thermal protection
- ✓ Interrupted phase alarm independent for each phase
- ✓ Univocal indication for each anomaly
- ✓ Malfunctioning status LED indicator
- ✓ Motor qualification LED indicator
- ✓ STEP input pulse signal indicator
- ✓ Direction change signal indicator
- ✓ Power supply LED indicator
- ✓ Digital development
- ✓ PC based setting and diagnostic
- ✓ Compact size
- ✓ Simple and fast DIN rail mounting
- ✓ Colored and numbered removable terminal blocks for easy and fast wiring
- ✓ Low cost

3.2 Accessories

The UDP30 interface is an essential accessory for the setting and diagnostics of the product.

Each drive is sold complete of the removable terminal blocks, anyway in case of loss or breach it is possible to re-order them making reference to one of the following codes

Code	Description
UDP30	Setting and diagnostic interface
LSP1004	DIN rail kit consisting of hook and spring
LSP4002	Terminal blocks kit consisting of: 1pc. numbered removable terminal block, red color, 2 poles 1pc. numbered removable terminal block, grey color, 5 poles 1pc. numbered removable terminal block, grey color, 10 poles
LSP4004	5pcs. numbered removable terminal block, red color, 2 poles
LSP4006	5pcs. numbered removable terminal block, grey color, 5 poles
LSP4008	5pcs. numbered removable terminal block, grey color, 10 poles

4 Installation

4.1 Inspection

Verify that the drive is not damaged, the package is intact and all accessories are included. Furthermore, control that the drive code corresponds to the ordered one, eventual special and customized version included. In case of problems please address to the product's vendor.

4.2 Mechanical Installation

The drive is designed to be mounted vertically on a 35mm DIN rail. To block the drive on the DIN rail insert first the bracket on the top, on the back of the drive, over the top of the DIN rail, keeping the drive slightly inclined as shown in the picture, then push the drive downward to engage the lower section of the rail. To verify the correct engagement of the drive try and pull it slightly upward to control that it is still in position.

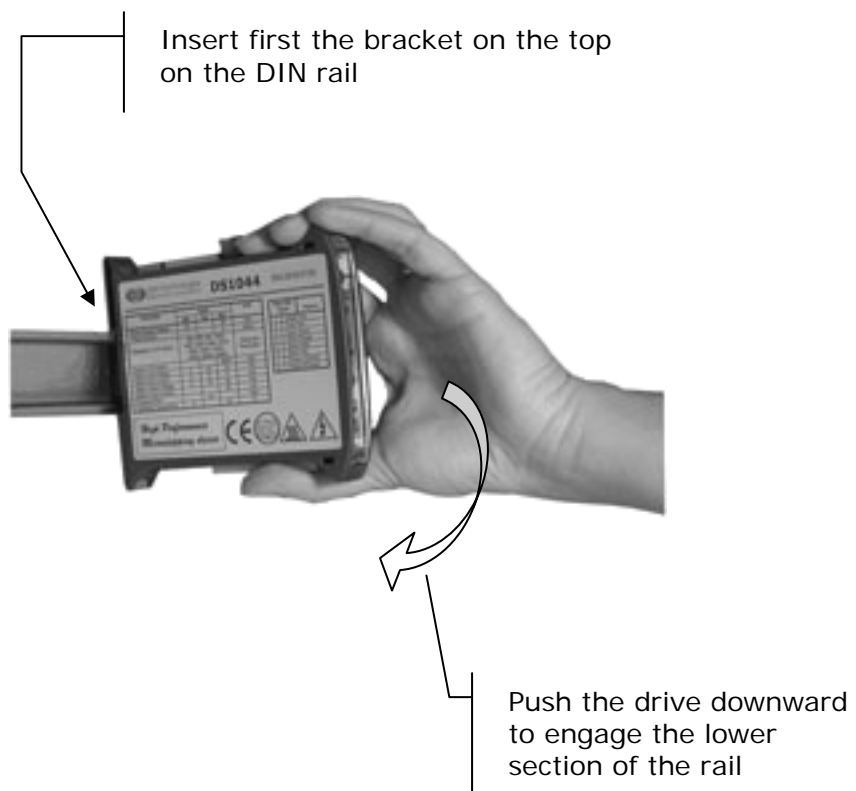

To remove the drive from the DIN rail insert a small flat bladed screwdriver into the red colored hook on the bottom, on the back of the drive. Push the hook downward and pull the drive upward slightly rotating it, releasing it from the DIN rail as shown in the picture.

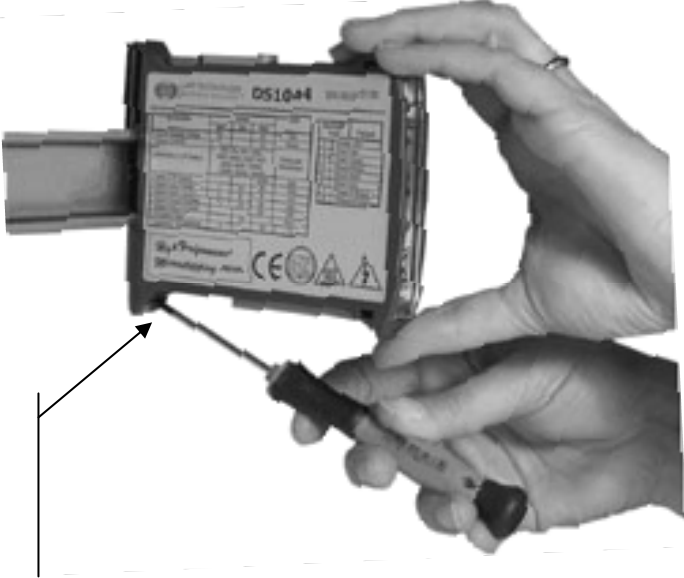

Insert a small flat bladed screwdriver into the red colored hook

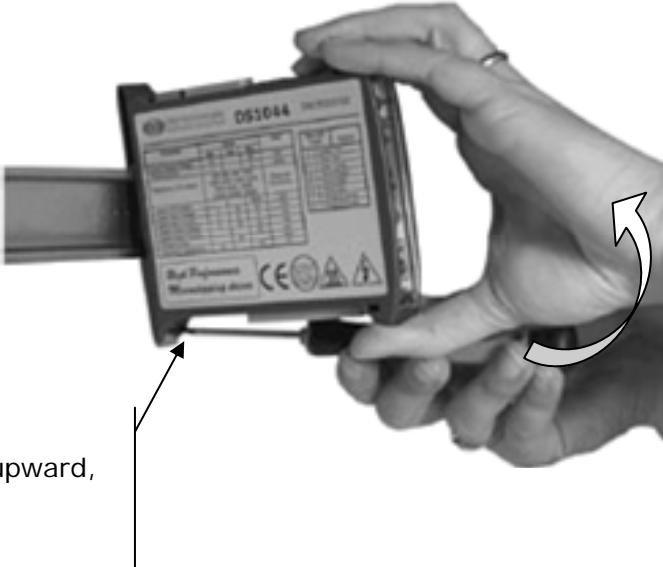

Push the screwdriver slightly downward and pull the drive upward, releasing it from the DIN rail



The heat generated by the drive while operating must be dissipated toward the surrounding air. To help cooling, the drive must be installed vertically in an area with a sufficient air gap of about 50mm above and below the drive itself, with no obstructions (wiring cables are anyway allowed). No space needs to be left on the sides and more drives can be put side by side taking a very compact space.

According to the drive calibration and to the running cycle, the space can be also substantially reduced without compromising the correct working of the drive.

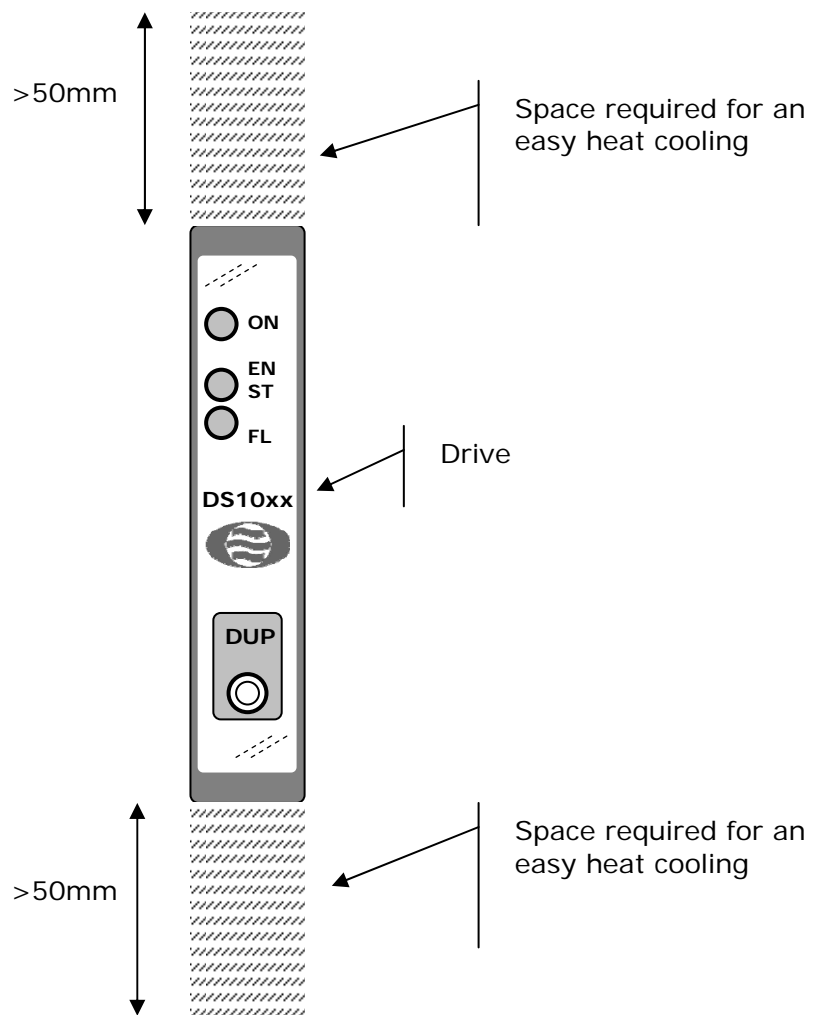

4.3 Air cooling



Its exceptional efficiency allows the product to be used even in absence of forced ventilation.

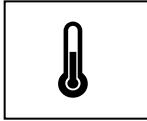

Whereas the drives is used with high calibration current or at high power supply voltage, whereas the working cycle is very heavy or the ambient temperature is high, it is possible to apply to forced ventilation to maintain the drive temperature whiting the functioning range values.



The fan can be positioned over or under the drive. A lateral position is not recommended. Thanks to the compact size of the drive, one only and economic fan of 120mm x 120mm can supply air circulation sufficient for 6 drives simultaneously (models of 18mm wide).

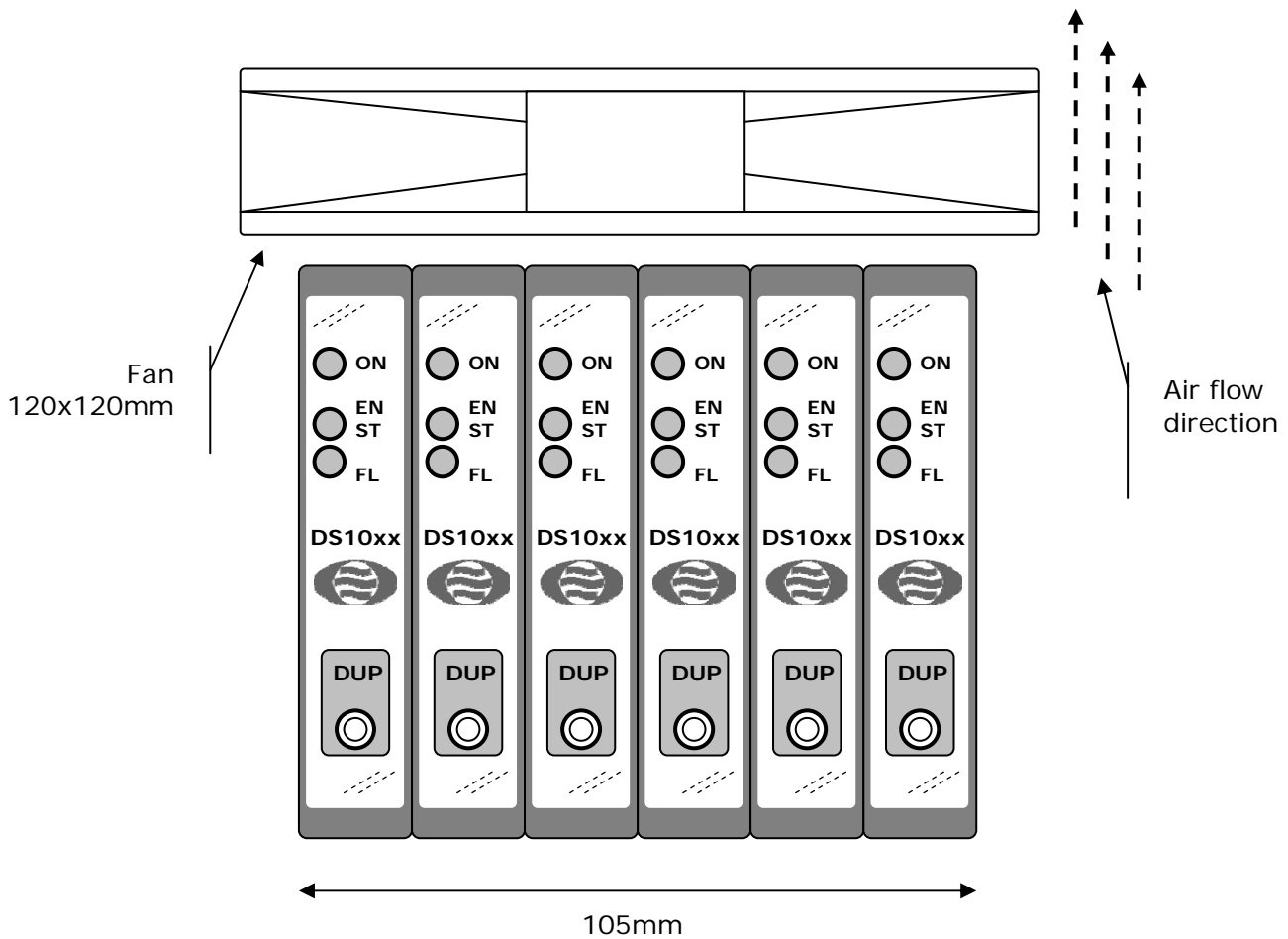

In case of a reduced fan size, it must be set in a rear position and at about 30mm high from the drive. A nearer or more distant position could reduce its effectiveness.

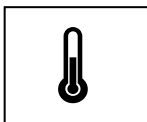
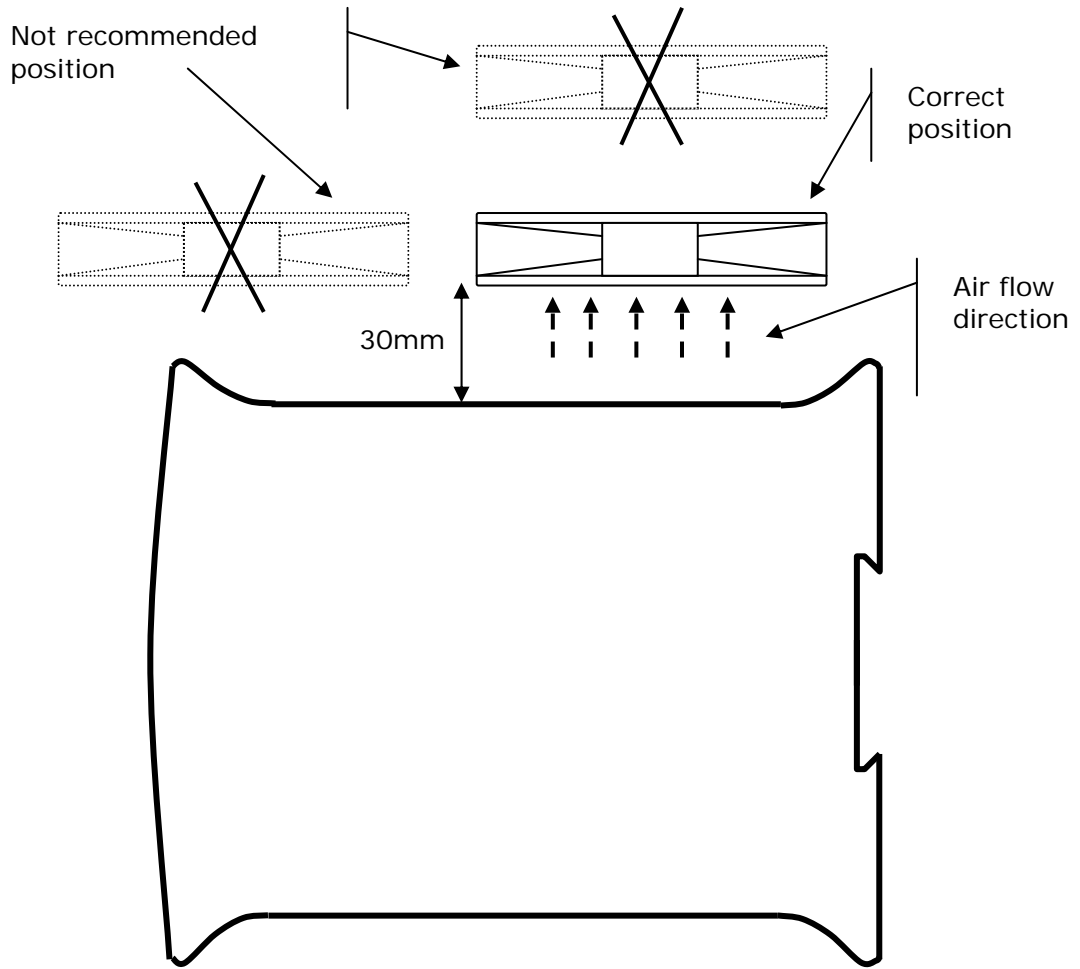

It is important to avoid the drive is covered with powder, dust or other. The buildup of such substances inside the drive could cause the malfunctioning or the breaking of the drive. Filters and necessary solutions must be got ready to avoid these damages to occur.

4.4 Wiring



The use of numbered and colored movable terminal blocks makes easier the wiring of the drive.
All the terminal blocks have 5mm pitch to allow an easy wiring of signal and power cables.

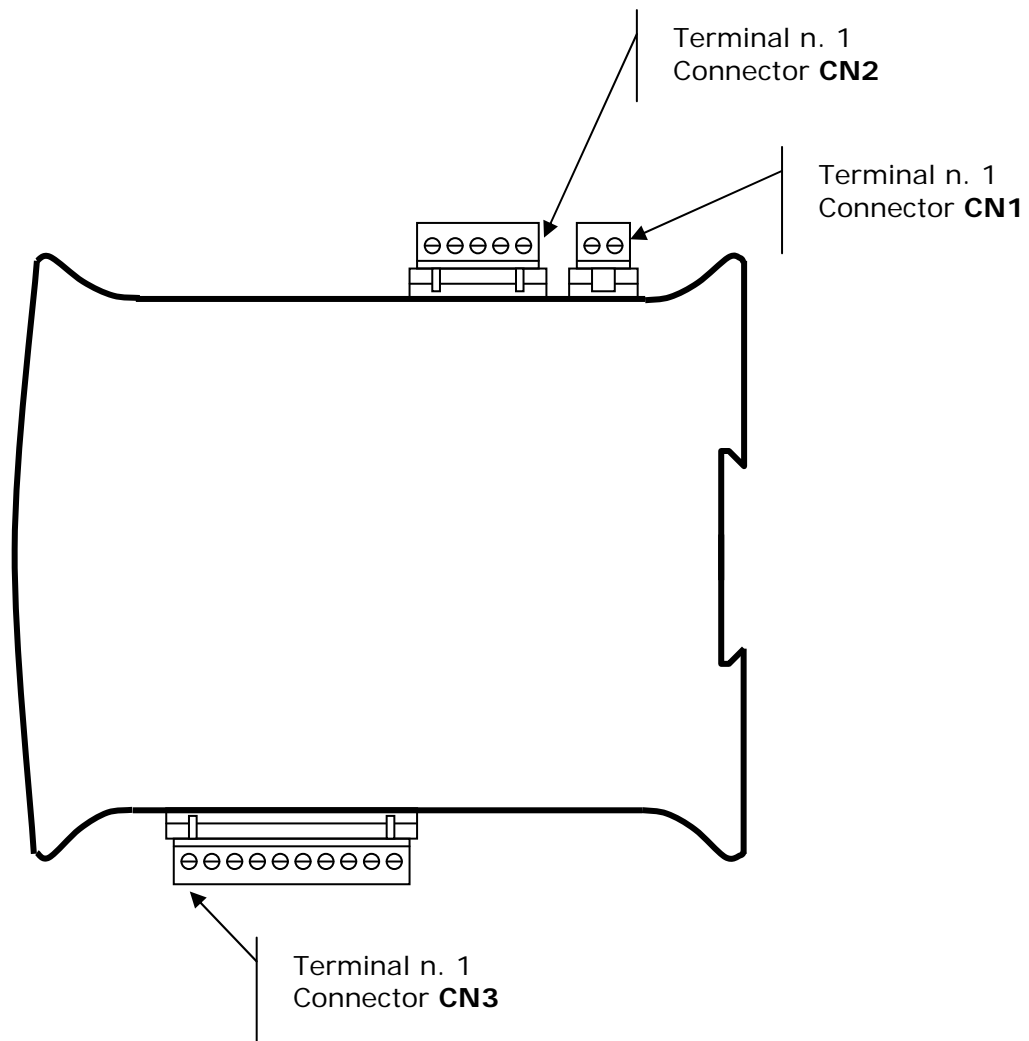

All the terminal blocks do not contain iron and are supplied with mobile truck. The clamping screw is slotted head, sized for screwdriver of 3x0.6mm.

We recommend to apply a tightening torque of about 0.8Nm.

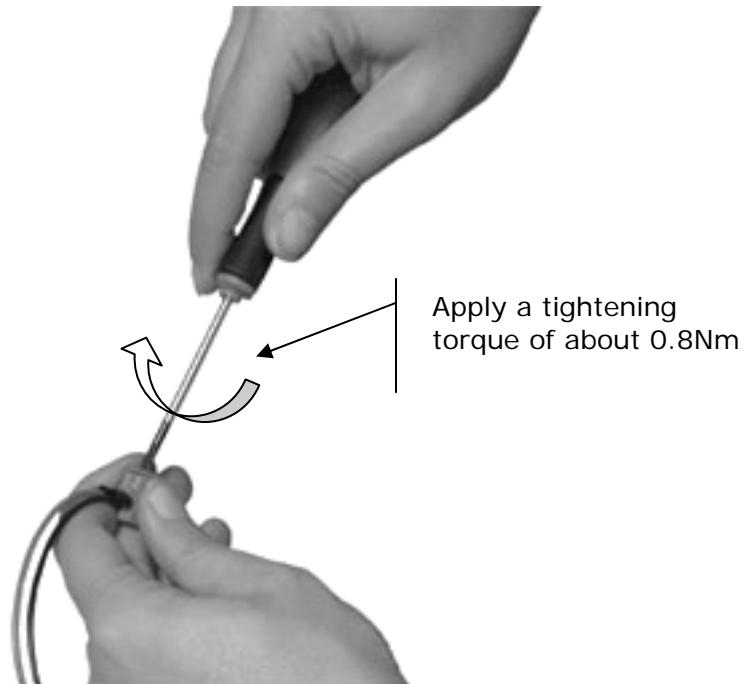

All terminals can tighten correctly cables with section between 0.1mm^2 and 2.5mm^2 (24...14 AWG).

We recommend to skin off the cable for $7/8\text{mm}$ as shown in the figure below.



4.4.1 Power Supply: AC models

The AC supply drives are identified by the letter A placed at the end of the code (ex. DS1044A). They integrate a rectifier bridge and the filter condensers necessary to rectify and filter the AC power supply voltage.



Therefore, this series of drives does not need an external power supply and can be directly connected to the output of a transformer with adequate voltage.

These products can also be supplied in DC, however take present that the rectifier bridge inside does not allow to recover the energy produced by the motor during the deceleration.

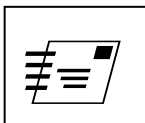

When supplying in DC a drive provided for the AC input, make reference to the parameters of the corresponding DC version (for example for the DS1076A refer to the DS1076) considering that the rectifier bridge inside has a total downfall of about 3Vdc. This means that, if for example a drive provided for AC input is supplied with 35Vdc voltage, this will act, for the purpose of the applied voltage, as the corresponding supplied at about 32Vdc.

The following table resumes the working and breaking effective voltage values considering a sinusoidal waveform.

Symbol	Description	Value			Unit	
		Min	Typ	Max		
Vac	Nominal AC supply voltage	DS1041A	16	28	36	Vac
		DS1044A DS1048A	18	32	36	
		DS1073A DS1076A DS1078A	20	55	65	
		DS1084A DS1087A	35	110	115	
Vacbrk	AC supply voltage causing the permanent damage	DS1041A			42	
		DS1044A DS1048A DS1073A DS1076A DS1078A			75	
		DS1084A DS1087A			142	
Vach	Over voltage protection intervention threshold	DS1041A	36.5		39	
		DS1044A DS1048A	40		42	
		DS1073A DS1076A DS1078A	69		73	
		DS1084A DS1087A	120		126	
Vacl	Under voltage protection intervention threshold	DS1041A	12.5		14.5	
		DS1044A DS1048A	14		15.6	
		DS1073A DS1076A DS1078A	16		18.6	
		DS1084A DS1087A	31		33.6	

The power supply is connected by the grey colored two poles connector.

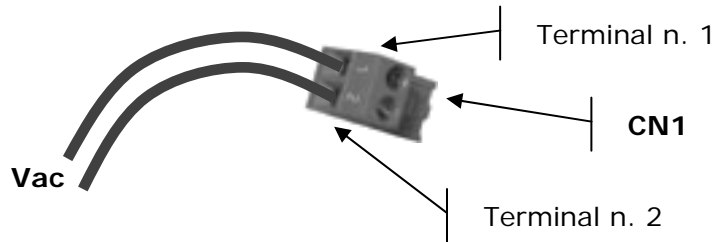

CN1 – Signal set-up (AC models)	
Contact n.	Description
1	Vac, AC power supply voltage input
2	Vac, AC power supply voltage input

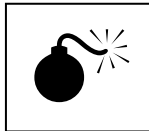

The overcoming of the *Vacbrk* voltage limit damages permanently the drive.
Do not install the drive before the wiring is complete.

For the connection with the transformer it is necessary to use a conductor with section adequate to the drive’s calibration (for safety’s it is better to use the max current supplied by the drive).

The following table resumes the cable sections suggested for each drive:

Model	Cable section (mm ²)
DS1041A	1
DS1044A	1
DS1048A	2.5
DS1073A	1
DS1076A	1.5
DS1078A	2.5
DS1084A	1.5
DS1087A	2.5

The power supply cable can be installed together with the ones connecting the drive to the motor. It is recommended not to place the power supply cable nearby the signal ones.

While choosing the transformer secondary voltage it is important to take into account the maximum net fluctuation expected in the worst operative conditions, the maximum vacuum voltage and the minimum full load voltage and to ensure that the maximum and minimum values, result of the combination of these components, are within the maximum and minimum voltage values specified for the chosen drive model.

The power that the transformer must handle is given by the one absorbed by the load (depending from the torque required to the motor as well as from the rotation speed), and by the motor and drive efficiency. The power lost on the drive for each model is indicated in the following table.

<i>Model</i>	<i>Min</i>	<i>Typ</i>	<i>Max</i>	<i>Unit</i>
DS1041A			7	W
DS1044A			12	W
DS1048A			21	W
DS1073A			10	W
DS1076A			20	W
DS1078A			24	W
DS1084A			20	W
DS1087A			36	W

The following is an example of base connection.

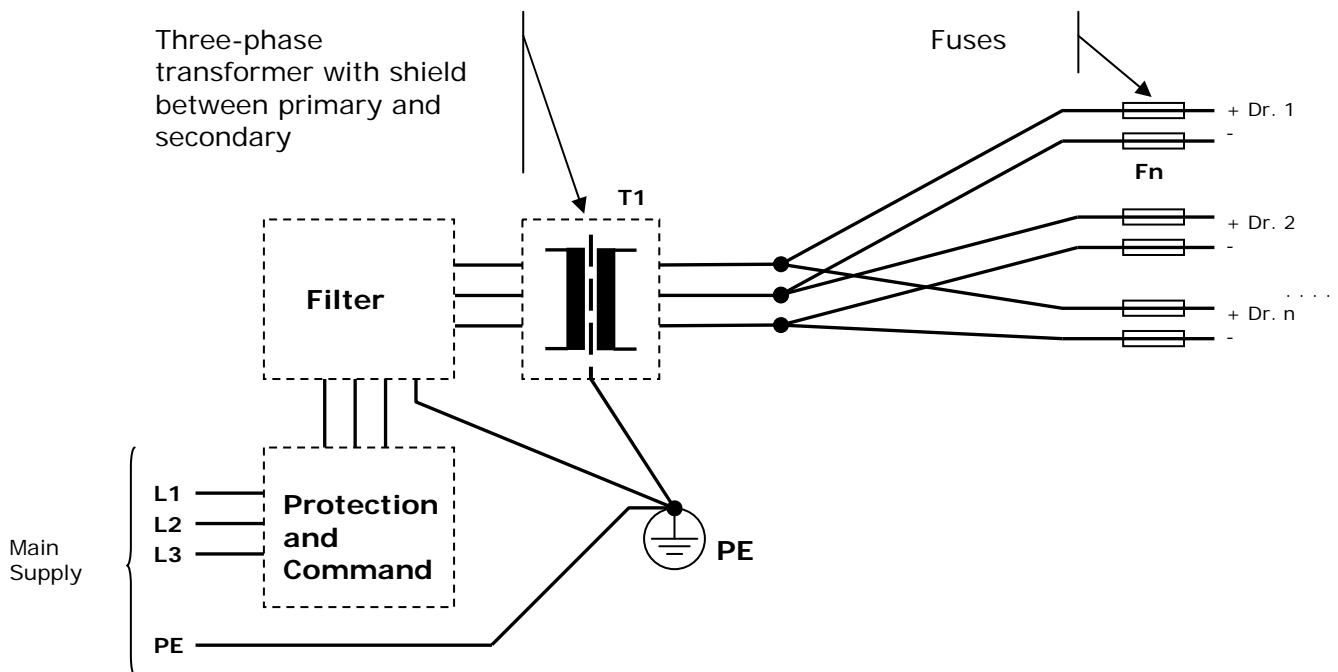

The above scheme includes a three-phase transformer (note the distribution of the drives on the three phases). If necessary it is also possible to use a mono-phase transformer.

Also note that the wiring must be star-like, where the earth connections of the various components ends in one only point electrically connected to the metal chassis and the earth of the plant.

As shown in the scheme, it is necessary to put in series to the transformer primary winding a filter able to stop the emissions coming from the drive and/or present on the main supply. Furthermore, the filter must be able to support the maximum power required by the drive plus the transformers losses.

The reduction level the filter must guarantee can vary a lot according to the laws applied to the field to which the application and/or installation belongs.

The producers of filters SHAFFNER and CORCOM can represent a good reference to find the right filter.

It is obligatory to provide on each phase of the transformer primary winding a fuse able to intervene in case of short circuit or malfunctioning. It is also suggested to use a fuse on each drives' power supply conductor.

The following table relates the suggested value for some components according to the number of drives present in the application.

The calculation considers also an oscillation of the main supply voltage included within +10/-20%.

Model	Fuses Fn (A rit.)	Number of drives	Secondary T1 (Vac)	Power T1 (VA)
DS1041A	2	1	32	50
		2		100
		3		150
		4..5		250
		6..8		350
DS1044A	6.3	1	32	125
		2		250
		3		375
		4..5		600
		6..8		900
DS1048A	12.5	1	32	250
		2		500
		3		750
		4..5		1100
		6..8		1800
DS1073A	4	1	55	150
		2		300
		3		450
		4..5		700
		6..8		1000
DS1076A	8	1	55	300
		2		600
		3		900
		4..5		1400
		6..8		2100
DS1078A	16	1	55	400
		2		800
		3		1200
		4..5		1800
		6..8		2800
DS1084A	6.3	1	110	350
		2		700
		3		1050
		4..5		1600
		6..8		2500
DS1087A	12.5	1	110	700
		2		1400
		3		2000
		4..5		2500
		6..8		5000

The working voltage of the T1 transformer primary winding must be chosen according to the main supply voltage available during the installation of the application. The transformer must have a shield between primary and secondary windings which must be connected to earth with a short and not inductive connection. The secondary winding voltage is meant without the load, with the primary winding supplied at the nominal voltage.

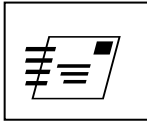

In the configurations with more than a drive, if the drives are not all calibrated to the maximum current and/or if the working cycle is not simultaneous, the power of the transformer can be considerably reduced. In some cases this can also be made when the motors' speed is limited.

The set composed by the filter and the transformer must be used only to supply voltage to the drives. It is advised against deriving other supplies from any of these parts. On the contrary, it is suggested to get auxiliary supplies using directly the main supply upstream of the filter.

4.4.2 Power Supply: DC models

The DC supply drives need a V_p voltage as specified in the table below. In the highest absorption conditions the power supply must grant a ripple voltage inferior to V_{prp} .

Symbol	Description	Value			Unit	
		Min	Typ	Max		
Vp	Nominal DC supply voltage	DS1041	18	45	50	Vdc
		DS1044 DS1048	20	45	50	
		DS1073 DS1076 DS1078	24	80	90	
		DS1084 DS1087	45	140	160	
		DS1098	45	200	240	
Vprp	Allowed ripple voltage	DS1041			8	Vpp
		DS1044 DS1048				
		DS1073 DS1076 DS1078			15	
		DS1084 DS1087			25	
Vpbrk	Voltage causing permanent damage	DS1041	-0.5		58	Vdc
		DS1044 DS1048	-0.5		105	
		DS1073 DS1076 DS1078	-0.5		200	
		DS1084 DS1087	-0.5		260	
Vph	Over voltage protection intervention threshold	DS1041	50.2		51.5	Vdc
		DS1044 DS1048	54		56	
		DS1073 DS1076 DS1078	96		102	
		DS1084 DS1087	170		180	
		DS1098	242		255	
Vpl	Under voltage protection intervention threshold	DS1041	16		17.8	Vdc
		DS1044 DS1048	18		19.5	
		DS1073 DS1076 DS1078	21		23.5	
		DS1084 DS1087	41		44	
DS1098						

The power supply is connected by the red colored 2 poles connector. The positive terminal must be connected to the terminal 1, while the negative terminal to the terminal 2.

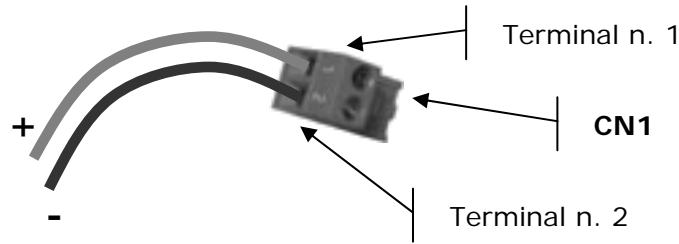

CN1 - Signals set-up (DC models)	
Contact n.	Description
1	+Vp, positive DC supply voltage
2	-Vp (GND), negative DC supply voltage

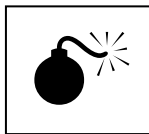

Reverse polarity connection damages permanently the drive, just as the overcoming of the V_{pbrk} voltage limit.
Do not install the drive before the wiring is complete.

If the distance between the drive and the power supply is more than 3m, it is necessary to place near the drive (less than 10cm) an electrolytic capacitor whose features are listed below:

Model	C2 Voltage (Vdc)	C2 Capacity (μ F)
DS1041	63	470
DS1044	63	470
DS1048	63	1000
DS1073	100	220
DS1076	100	470
DS1078	100	1000
DS1084	200	470
DS1087	200	1000
DS1098	250	1000

To connect together the power supply, the drive and the eventual local capacitor, it is necessary to use a conductor with section adequate to the drive's current calibration (anyway, for safety's reason, it is better to use the maximum current supplied by the drive).

The following table resumes the cable section suggested for each drive:

Model	Cable section (mm ²)
DS1041	1
DS1044	1
DS1048	2.5
DS1073	1
DS1076	1.5
DS1078	2.5
DS1084	1.5
DS1087	2.5
DS1098	2.5

The power supply cable can be installed together with the ones connecting the drive to the motor. We recommend not to place the power supply cable nearby the signal ones.

There are two types of power supplies commonly used, regulated and unregulated.

The regulated power supply maintains a stable output voltage, immune to the net and load fluctuations, which allows to supply the drive even with voltage values near to the allowed maximum ones, with an immediate benefit in terms of torque supplied by the motor at high speed. The disadvantage of the regulated power supplies is their cost.

An unregulated power supply is cheaper, but it requires the consideration of safety's tolerance during its sizing so that, in presence of net and load fluctuations, voltage remains however within the acceptable working values.

A detailed description about the sizing of the power supply is outside of this manual. The user who decides to construct its own power supply must be technically qualified to size it, to assure its correct working and to fulfill each safety requirements. To determine the power supply output voltage it must be considered the maximum net fluctuation expected on worse operating conditions, the maximum vacuum voltage and the minimum voltage at full load, and to assure that the values result of these components combination are within the range of the maximum and minimum voltage values specified for the chosen drive model.

The power that the power supply must deliver is given by the one absorbed by the load (depending from the torque required to the motor as well as from the rotation speed), and by the motor and drive efficiency.

The power lost on the drive for each model is indicated in the following table.

<i>Model</i>	<i>Min</i>	<i>Typ</i>	<i>Max</i>	<i>Unit</i>
DS1041			5	W
DS1044			8	W
DS1048			15	W
DS1073			8	W
DS1076			15	W
DS1078			15	W
DS1084			15	W
DS1087			20	W
DS1098			30	W

Because of the many variables in play it is clear the impossibility to prior indicate an only one kind of dimensioning valid for each application. Just for example, not to be considered exhaustive and correct for the application, see the following electric scheme of an unregulated power supply with a brief indication of the components value.

You can also ask to your own vendor to evaluate if the following values are usable for your application.

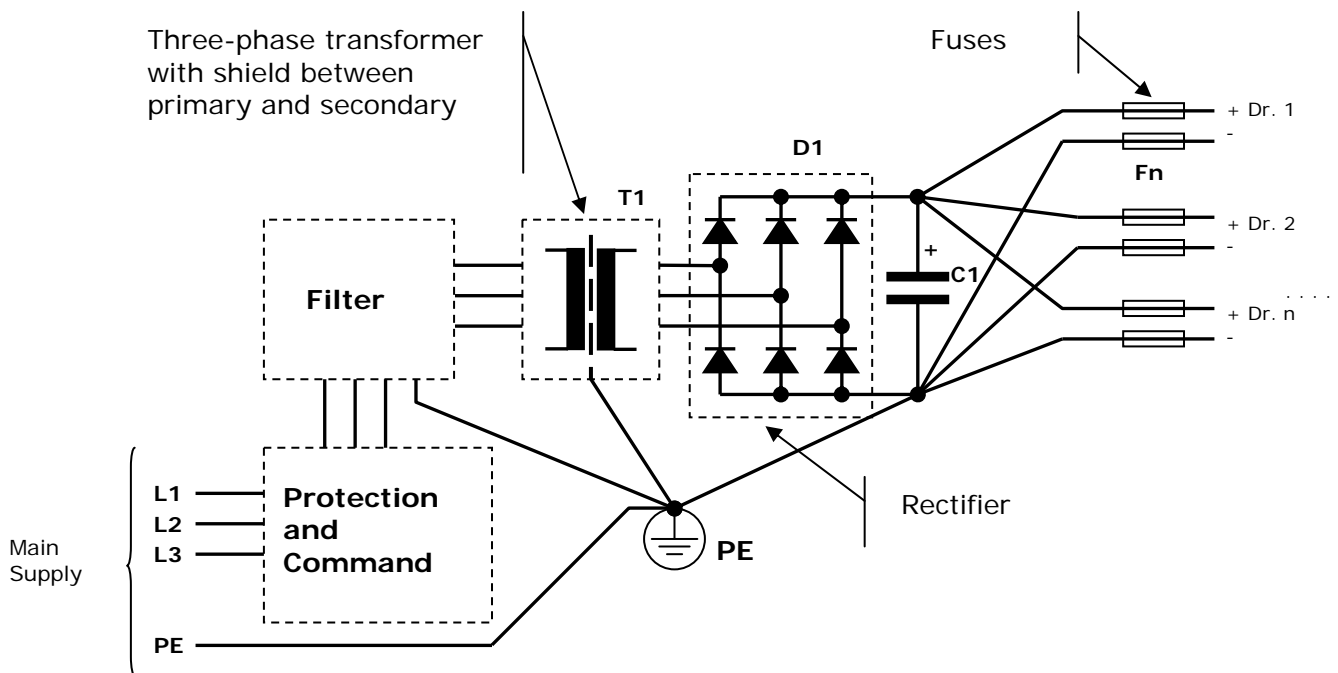

Also note that the wiring must be star-like, where the earth connection of the various components ends in one only point electrically connected to the metal chassis and the earth of the plant.

Also the wiring towards the drives must be star-like, with the center of the star on C1 capacitor poles.

As shown in the scheme, it is necessary to put in series to the transformer primary winding a filter able to stop the emissions coming from the drive and/or present on the main supply. Furthermore, the filter must be able to support the maximum power required by the drive plus the transformers losses.

It is obligatory to provide on each phase of the transformer primary winding a fuse able to intervene in case of short circuit at the supply output or a malfunctioning of its parts. It is also suggested to use a fuse on each drives' power supply conductor.

The reduction level the filter must guarantee can vary a lot according to the laws applied to the field to which the application and/or installation belongs.

The producers of filters SHAFFNER and CORCOM can represent a good reference to find the right filter.

The following table relates the characteristic values of the main components in the transformer. The calculation considers also an oscillation of the main supply voltage included within +10/-20%.

You can also ask to your own vendor to evaluate if the following values are usable for your application.

Model	Fuses Fn (A rit.)	Number of drives	Secondary T1 (Vac)	Power T1 (VA)	Current D1 (Arms)	Voltage C1 (Vdc)	Capacity C1 (µF)
DS1041	2	1	32	50	25A	63	1000
		2		100	25A		2200
		3		150	25A		3300
		4..5		250	25A		4700
		6..8		350	25A		5600
DS1044	6.3	1	32	125	25A	63	3300
		2		250	25A		4700
		3		375	25A		5600
		4..5		600	25A		8200
		6..8		900	35A		10000
DS1048	12.5	1	32	250	25A	63	4700
		2		500	25A		6800
		3		750	25A		8200
		4..5		1100	35A		10000
		6..8		1800	50A		15000
DS1073	4	1	55	150	25A	100	1800
		2		300	25A		2200
		3		450	25A		3300
		4..5		700	25A		4700
		6..8		1000	35A		5600
DS1076	8	1	55	300	25A	100	2200
		2		600	25A		3300
		3		900	25A		3900
		4..5		1400	35A		4700
		6..8		2100	50A		6800
DS1078	16	1	55	400	25A	100	3300
		2		800	25A		4700
		3		1200	25A		5600
		4..5		1800	35A		8200
		6..8		2800	50A		10000
DS1084	6.3	1	110	350	25A	200	1000
		2		700	25A		1500
		3		1050	25A		1800
		4..5		1600	25A		2200
		6..8		2500	35A		3300
DS1087	12.5	1	110	700	25A	200	1500
		2		1400	25A		2200
		3		2000	25A		3300
		4..5		2500	35A		4700
		6..8		5000	50A		6800
DS1098	16	1	140	1000	25A	250	1800
		2		2000	25A		2200
		3		3000	35A		3300
		4..5		4500	50A		4700
		6..8		7000	50A		6800

The values suggested for the capacitor C1 can also be obtained placing more capacitors in parallel amongst them. Eventual approximations must be made in excess. The user can add in parallel to the C1 capacitor a resistor, opportunely dimensioned, to discharge the capacitor more quickly. The working voltage of the T1 transformer primary winding must be chosen according to the main supply voltage available during the installation of the application. The transformer must have a shield between primary and secondary windings which must be connected to earth with a short and not inductive connection. The secondary winding voltage is meant without the load, with the primary winding supplied at the nominal voltage.

The rectifier, besides supporting the maximum current required by the drive, must be able to tolerate the current supplied during the C1 capacitor charge. Such current, as being essentially limited only by the internal resistor of the transformer secondary winding, usually very low, and by the wiring, can also be of elevated entity, even if of short length (it exhausts when the capacitor is charged).

Furthermore, the rectifier needs an heat sink able to maintain the temperature within the range defined by the manufacturer (usually 70°C). The working voltage of the D1 rectifier must be then chosen according to the T1 transformer secondary winding voltage multiplied at least by 2.

In the configurations with more than a drive, if the drives are not all calibrated to the maximum current and/or if the working cycle is not simultaneous, the power of the transformer can be considerably reduced. In some cases this can also be made when the motors' speed is limited.

The diagram and the components values refer to a three-phase power supply. Dimensioning in a different way the components it is possible to realize a mono-phase power supply, which is not recommended when the required power is greater than 500W.

The set composed by the filter, the transformer and the power supply must be used only to supply voltage to the drives. It is advised against deriving other supplies from any of these parts. On the contrary, it is suggested to get auxiliary supplies using directly the main supply upstream of the filter.

4.4.3 Motor

The connection between the drive and the motor must be made using shielded cable and connecting the screen to the drive’s SHIELD terminal. The cable shield on the motor side must be connected to the motor body only if this one is electrically insulated from the structure where it is fastened. In case the motor is electrically earth connected (for example through a mechanical fastener) the motor side shield must not be connected.

Only if problems connected to electromagnetic emissions occur it is possible to try and connect the shield also from the motor side. Because of the possible ground loops which could start, it is advised to execute this wiring only when strictly necessary.

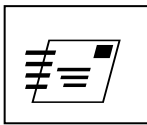

The drive regulates the current in the motor phases through the supply voltage modulation in chopper technique. The use of a good quality shielded cable and a correct wiring are essential to better reduce the electromagnetic emissions.

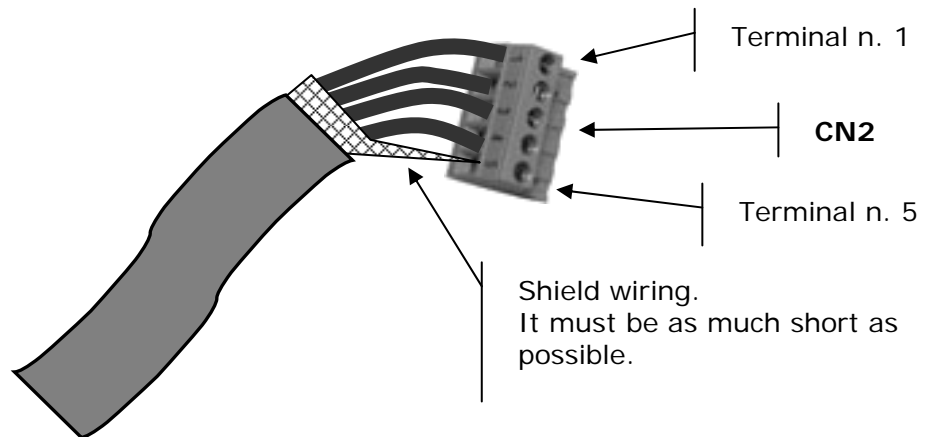

CN2 – Signals set-up	
Contact n.	Description
1	FA-, negate output phase A
2	FA+, positive output phase A
3	FB+, positive output phase B
4	FB-, negate output phase B
5	SHIELD (internally connected with GND)

Inverting the FA+ phase with the FA- phase, or the FB+ phase with the FB- phase, the motor rotation direction is inverted (making both inversions the rotation does not change).

The cable section can be dimensioned according to the drive current calibration, anyway it is suggested to choose a cable suitable for the maximum current deliverable from the chosen drive.

It is also advised to connect the motor to the drive with a cable with a length inferior to 10m. For cables with a greater length, the cable size must be increased to counterbalance the voltage drop.

The following table indicates the cable section suggested for each drive according to the cable length:

Model	Cable section (mm ²)	
	Cable length ≤ 10m	Cable length > 10m
DS1041(A)	0.5	1
DS1044(A)	1	1.5
DS1048(A)	1.5	2
DS1073(A)	1	1.5
DS1076(A)	1.5	2
DS1078(A)	2.5	3
DS1084(A)	1	1.5
DS1087(A)	1.5	2
DS1098	2.5	3

The cable connecting the drive to the motor can be installed together with the power supply cable, but it must be kept separate from the signal ones.



If difficulties are met to pass compatibility tests, it is possible to place in series to each phase an inductor with a value included between 10uH and 100uH and with current adequate to the set phase current. The inductor must be placed directly at the drive output.

4.4.4 Control Signals

4.4.4.1 Inputs

The cable used for the control signals wiring must be shielded type. The shielding must be connected only to the numerical control device side (PC, PLC or other) while on the drive side it must remain unconnected as shown in the figure below.

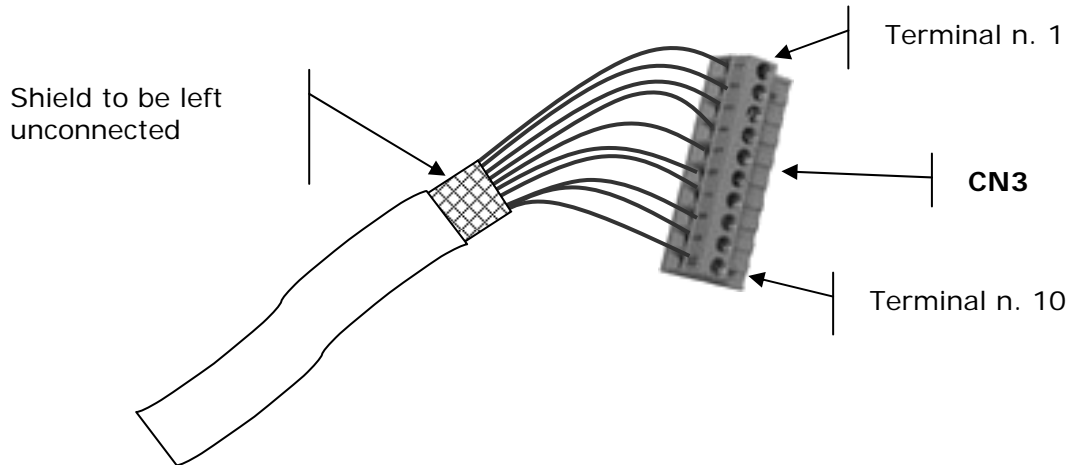

CN3 – Signals	
Contact n.	Description
1	STEP+, motor rotation signal, positive input
2	STEP-, motor rotation signal, negate input
3	DIRECTION+, reverse direction signal, positive input
4	DIRECTION-, reverse direction signal, negate input
5	ENABLE+, current enable (torque) signal, positive input
6	ENABLE-, current enable (torque) signal, negate input
7	BOOST+, current boost signal, positive input
8	BOOST-, current boost signal, negate input
9	FAULT+, drive status, positive output
10	FAULT-, drive status, negate output

The section of the cable does not have much importance as the circulating currents are meager (in the order of few mA), therefore choose the section according to wiring functionality.

The control signal cable must not be placed together with the power supply or the motor cables. If it happens there is the possibility that the high slew-rate voltage and high rate current could be coupled with the logic level signal and corrupt it.

There are totally 4 outputs: STEP, DIRECTION, ENABLE, BOOST and an output called FAULT.



The DS10 drives inputs and outputs can be independently connected in NPN and PNP logic or in line driving mode. Each input lays both the connections making possible mixed settings.

All inputs and outputs are optocoupled amongst them, towards the motor and towards the power supply.

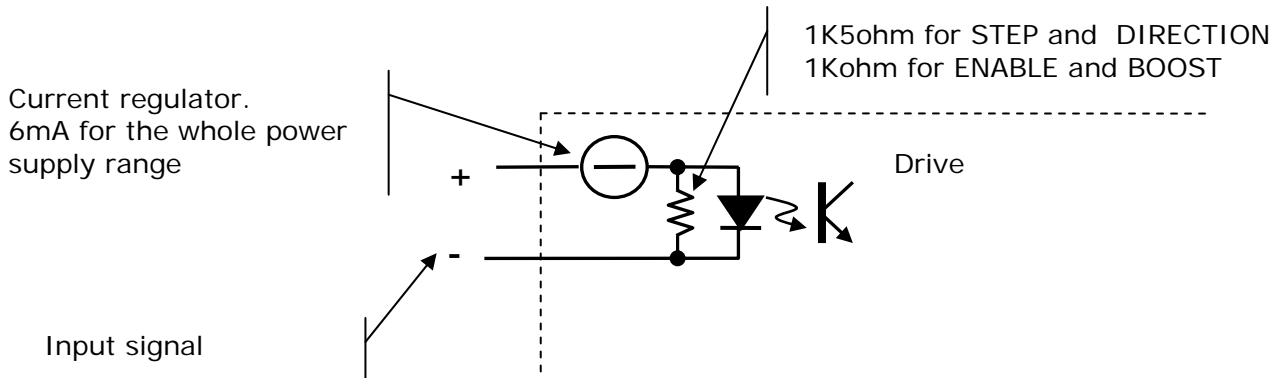

The DS10 drives have on each input a particular current limitation circuit which grants a constant absorption to the varying of the applied voltage. This device allows a wide input power supply range (from 3Vdc up to 28Vdc) without requiring excessive current to the control equipment or external limit resistors.

A good number of drives nowadays on the market, of the same category, uses to place in series to the input a simple current limitation resistor which reduces the input working voltage setting and causes, moreover, high current values when the input voltage is high. The DS10 drives, on the contrary, maintain an almost constant absorption on the whole working range, as shown in the diagram below.

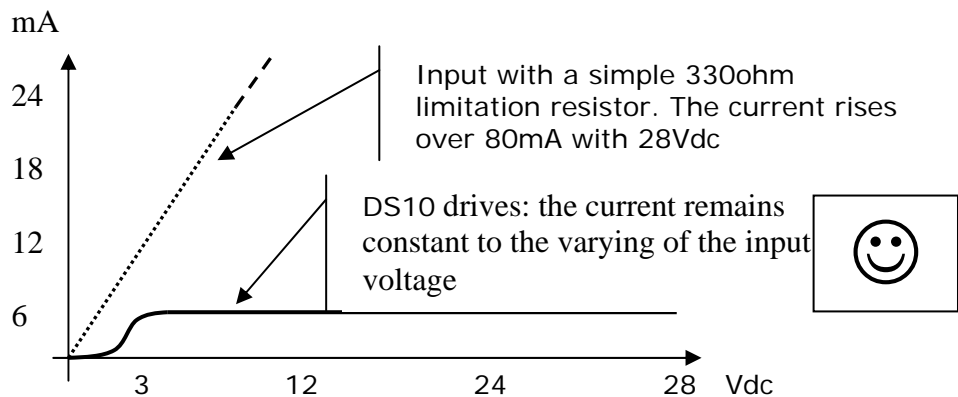



Each single input can be used on line driving mode independently from the others.

The following table resumes the electric characteristics of the control signals.

Symbol	Description	Value			Unit
		Min	Typ	Max	
Vdi	Active input voltage	3		28	Vdc
Vdioff	Inactive input voltage	-30		1	Vdc
Vdibrk	Digital inputs breakdown voltage	-30		+30	Vdc
Idi	Current absorbed by the digital inputs (24Vdc)	4	6	8	mA

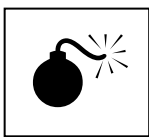

The overcoming of the *Vdibrk* voltage limit damages permanently the drive.

Sometimes the *Vdibrk* voltage limit can be accidentally overcome because of the currents driven by the inductive loads present in the application and out of the recycle diode in anti-parallel. If the installation includes electro valves, contactor (remote control switch), electromagnetic brakes, etc. it is advised to place on each one of them a recycle diode, or to adopt a similar solution, to avoid the extra voltage produced when the inductive load switched off.

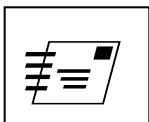
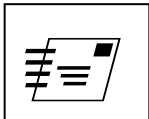

If the same power supply is used to provide the power and the signal supply, for example a 24Vdc device, carefully verify that the energy produced by the motor during the braking does not increase the voltage at the ends of the power supply over the *Vdibrk* limit supported by the input.

4.4.4.2 Outputs



The outputs have a zener diode placed in anti-parallel which allows to connect the output with medium entity loads (for example signal relays) without having to use an external recycle diode.

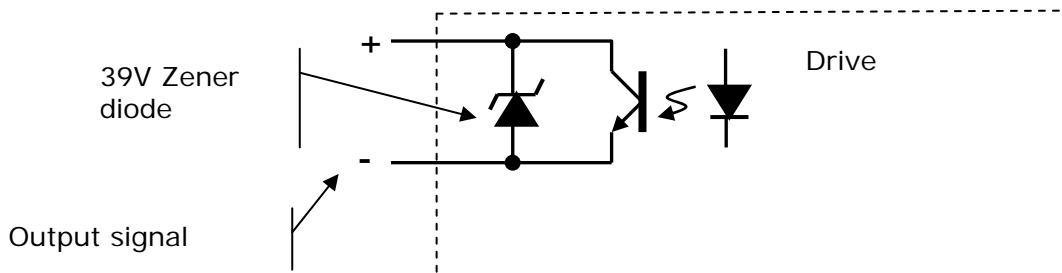

The following table indicates the electrical characteristics of the digital outputs.

Symbol	Description	Value			Unit
		Min	Typ	Max	
Vdo	Digital outputs operating voltage	1		30	Vdc
Vdobrk	Digital outputs breakdown voltage	-0.5		37	Vdc
Vdoz	Zener diode voltage placed in parallel to each output	37	39	42	Vdc
I do	Digital outputs available current			60	mA
I dobrk	Digital outputs breakdown current	120			mA
Pwdo	Digital outputs dissipable power			400	mW

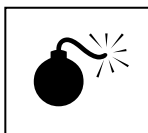

The outputs are protected against brief short circuits. An extended short circuit, or the overcome of the *I dobrk* current, can permanently damage the output.

4.4.5 Chassis setting

In order to contain the electromagnetic emissions and to better shield the drive, it is essential to give particular attention to the setting of the chassis. The drive must be placed inside a metal case, preferably iron made, capable to successfully shield the electromagnetic emissions. The case must be electrically placed to ground as better described ahead.

Filter

The filter must be correctly placed in series to the main supply. The ideal position is on the chassis edge in order to have a short wiring coming out from the main supply. If, on the contrary, the main supply cables run inside the chassis, they can be invested by electromagnetic interferences making ineffective or much reducing the filter efficiency.

The filter output earth must be connected to the metallic body of the chassis. It is important the connection is of short length and made with a large section and low inductance conductor. The point of connection between ground coming from the filter and the chassis constitutes the star center to which all other components earth must be connected. Moreover, the filter metallic body must be electrically placed in contact with the case.

Transformer

The transformer must be placed close to the filter and must have a shield between the primary and the secondary windings. The shield must be ground connected in the star center obtained inside the case. Furthermore, the transformer metallic body must be electrically connected to the case.

Power Supply

It is best to install the power supply near the transformer. The power supply earth (usually the negative pole of the filter capacitor) must be connected to ground in the star center obtained inside the case.

Drive

The drive position must be chosen in order the motor cables can immediately come out from the case without running long distances inside the case itself.

Numerical Control

The numerical control device, PLC or other, which generates the driving signals of the drive must be as far as possible from the drives and from the power supply group. Moreover, the signals wiring must be remain distant from the power supply and motor cables. When the distance from the numerical control device and the drive and/or the power supply is reduced, there must be one or more shielding walls, electrically connected to the case.

The following figure shows a possible setting of the chassis.

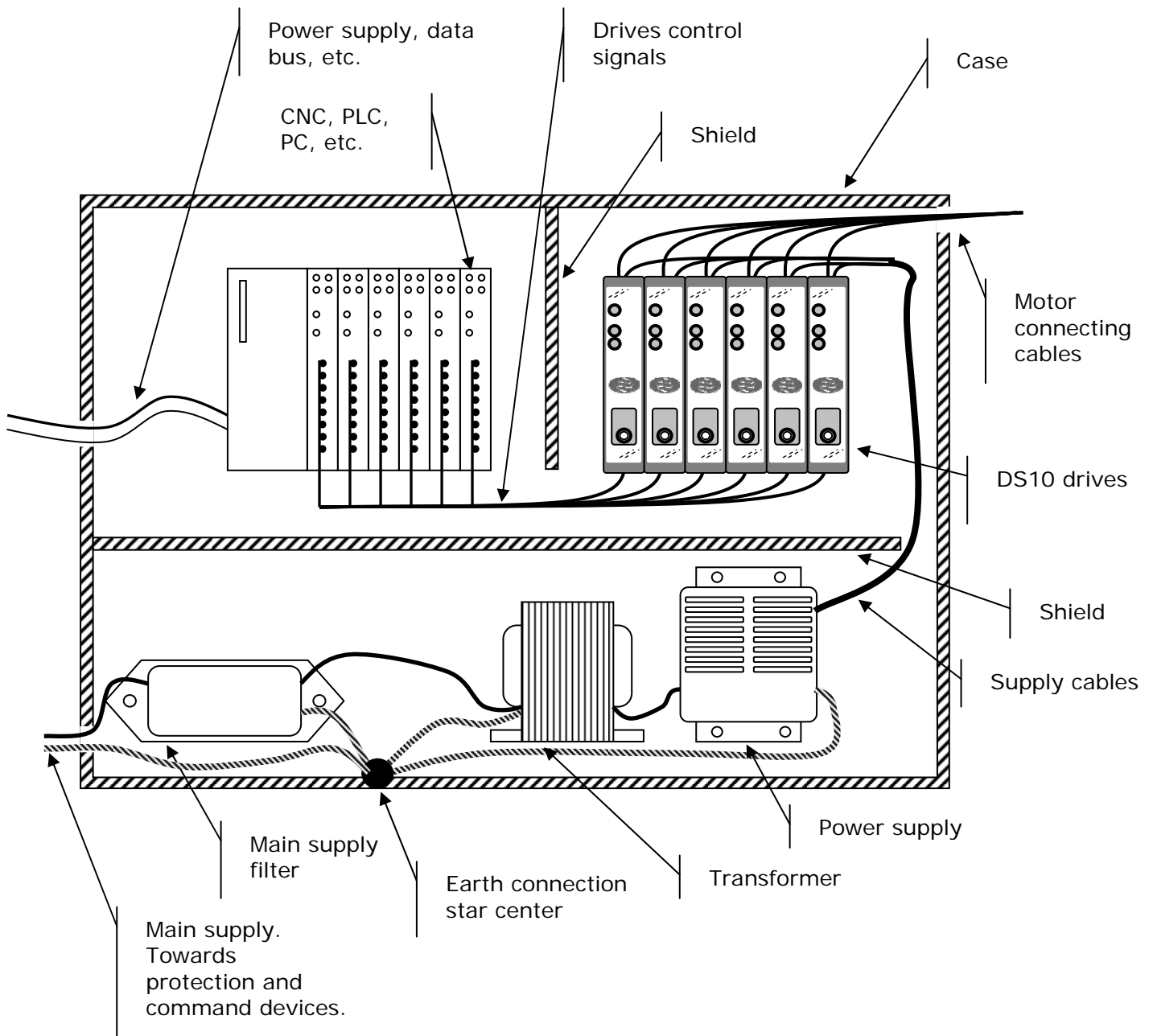

Safety must never be compromised. Safety is always of first priority.

5 Functionality and Configuration

5.1 General description

The drive setting is made through the DUP port.



Through this connection it is possible to modify all drive's setting parameters, to read their status, the production information and then to update the internal firmware. This latest feature deserves particular attention as it allows to maintain the product updated with the last implemented functionalities.

To facilitate the drive setting it has been created a software, called *UDP Commander*, designed for Windows platform, particularly immediate and easy to use.

The software makes use of the UDP30 interface to communicate with the DUP port of the drive. The UDP30 interface is connected to the PC by the USB port.



To grant high noise immunity and to protect the equipment integrity, the connection between the PC and the drive must be of insulated type.

The UDP30 interface makes use of the power supply on the USB port to feed the drive digital section, making possible the setting and the reading of information therein contained even without the power supply.

For a more detailed description of the features and installation of the UDP30 and of the *UDP Commander* software, see the dedicated user's manuals.

5.2 Setting

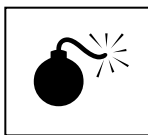

The setting must be made before connecting the motor and starting the equipment.

A non correct setting can damage the motor and/or the equipment.

5.2.1 Phase current

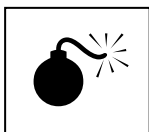

It is necessary to pay close attention to the phase current setting as a wrong value can damage permanently the motor.

The phase current must be set in order to correspond to the stepper motor's plate current declared by the manufacturer.

In the following table are detailed the minimum and maximum current values which can be set according to the various models of drive.

Model	Current value (Arms)	
	Min	Max
DS1041(A)	0.3	1.4
DS1044(A)	1	4
DS1048(A)	3	8
DS1073(A)	0.8	3
DS1076(A)	2	6
DS1078(A)	4	10
DS1084(A)	2	4
DS1087(A)	4	8.5
DS1098	4	10

It is important to note that the values listed above are expressed as effective current and not as peak current.

Some manufacturers indicate the I_{pk} peak current (or I_{max} maximum current). To obtain the effective current value it is sufficient to divide the peak current by 1.41 (this calculation is not applicable in case of full step or not sinusoid currents given to the motor).



The above explains why a 4Arms drive (4A effective current) is equivalent to a drive with peak current (or maximum current) equal to 5.6A_{pk} (4×1.41). Do consider this while comparing the features of the DS10 drives with other producers' devices.

The following figures show the phase current supplied by the DS1048 drive calibrated to 5Arms (right figure) and the current of a competitor's drive calibrated to 5A_{peak} (left figure).

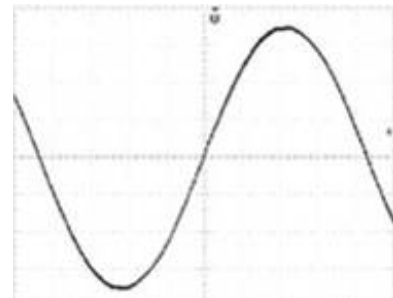
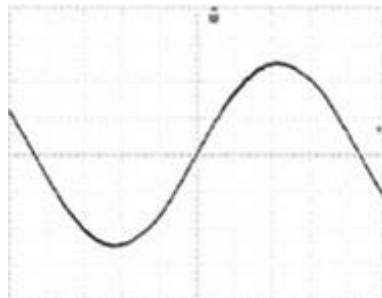



It appears evident how the DS10 drives (which characterize the current to the effective Arms value) supply greater current than those drives which characterize the phase current as peak value or maximum value.

As above explained, the current calibration must be executed according to the motor features declared by the manufacturer, however in particular cases it is possible to use an higher current value than the declared nominal one. This could be useful to obtain more torque from the motor, but it is important to keep in mind that this method leads to an higher motor heating. If the motor temperature exceeds the maximum allowed values (usually 90°C) the motor could be permanently damaged. Usually, the motor is over supplied only if the working cycle is flat and therefore allows a medium working temperature within the maximum allowed values declared by the manufacturer.

Because of the saturation phenomena of the magnetic circuit inside the motor (which vary from model to model), there is not a direct correspondence between torque and phase current when the nominal value is exceeded. In other words, even doubling the current, a double torque is never obtained from a motor. For this reason it is usually superfluous to over supply the motor of more than 30% of the nominal current.

If the motor works in a very hot site or without a mechanic device capable to discharge the heat, it is possible it reaches high temperatures even if supplied by the nominal current. In this case it is necessary to introduce a forced ventilation on the motor or, if the torque margins allow it, to reduce the current calibration on the drive.

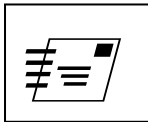

Remember that in this case the benefit obtained in terms of temperature will go at the expense of the torque supplied by the motor. Moreover, consider that when the drive calibration current does not correspond to the motor nominal current, the microstepping movement can lose regularity. In the same way, sometimes it is possible to improve the microstepping movement by slightly modifying the current calibration.



The DS10 drives allow to optimize the microstepping movement of each motor by changing the waveform of the applied current, as better described ahead.

Usually a two phase stepping motor disposes of four wires, two per each phase. In this case the drive current calibration must correspond to the motor plate current. If, for example, the motor relates 3A/phase also the drive shall have to be calibrated to 3Arms.

The 8-wires stepping motors have instead four phases which can be connected in series or in parallel amongst them, two by two. The current calibration between a connection in series and a connection in parallel is different, such as the motor performances, as specified ahead.

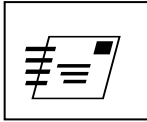

The series configuration requires a lower phase current but it also exposes a superior anti-electromotive force and a phase inductance towards the drive (4 times the single phase one) which penalizes the motor torque at high speeds. Therefore, this kind of connection is used in applications where the motor speed is limited or the supply voltage is sufficiently high.

When a series configuration is used it is necessary to calibrate the drive to the motor phase current multiplied by the coefficient 0.71, if the manufacturer specifies the current value in unipolar mode, or multiplied by 0.5 if the current is specified in relation to a parallel bipolar connection.

If, for example, the motor used has a plate current of 3A in unipolar mode, with the windings connected in series, the drive shall have to be calibrated to a current of 2.1Arms ($3 * 0.71$).

Instead, if the motor to be used has a plate current of 10A, declared for a parallel bipolar use, the drive shall have to be calibrated to a current of 5Arms ($10 * 0.5$).

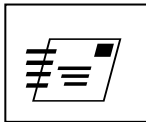

On the contrary, the parallel configuration requires an higher phase current but it has the advantage to maintain the torque supplied by the motor more constant to the increasing of the speed. It happens thanks to an inferior anti-electromotive force and inductance exposed towards the drive (in respect to a series connection).

The parallel connection is therefore preferable when the motor working speed is high or when then supply voltage is low.

When a parallel configuration is used it is necessary to calibrate the drive to the motor phase current multiplied by the coefficient 1.41, when the manufacturer specifies the current value in unipolar mode, or multiplied by 2 if the current is specified in relation to a series bipolar connection. If, for example, the motor used has a plate current of 3A/phase in unipolar mode, with the windings connected in parallel, the drive shall have to be calibrated to a current of 4.2Arms ($3 * 1.41$).

5.2.2 Automatic current reduction

Stepper motor drives work at impressed current, i.e. they always supply the motor at the set nominal current independently from the fact that motor gives torque to the load or not.

In other types of motor, as for example in DC or Brushless motors, the drive supplies to the motor the current strictly necessary to maintain the position or the rotation speed required. In these cases the drive obtains the information on the position or speed errors through transducers such as tachogenerator, encoder, resolver, etc. Therefore, such a system disposes of a feedback and it is classified as a reacted system or at closed loop.

On the contrary, the stepper motors can be used without the help of any transducer, even granting constant speeds and precise and repeatable positioning. This is possible because the stepper motor is a synchronous actuator which follows without shifting the rotating magnetic field generated by the stator windings. Till when the load opposes a resistant torque inferior to the one supplied by the motor, the rotor remains “hooked” to the rotating magnetic field, while when the load exceeds the available torque the rotor loses the synchronism and the position and the speed are not more granted.

Therefore, it appears evident that for a correct use of the stepper motor it is of primary importance to take care of the sizing of the application, so that the request for the load torque remains inferior to the torque supplied by the motor (on the whole speed range required).

When the stepper motor is firm it is often necessary to grant a maintaining torque capable to keep the load in stable position (a suspended load for example), for this reason the drive supplies current to the motor even when it is motionless.

However, in many cases the current necessary to grant the load stability is inferior, even a lot, to the required operating value. This is mainly due to two reasons: when the motor is firm there are no inertial loads (which appear instead during speed changes), furthermore the torque / speed curve of the motor reaches its utmost just in proximity of zero speed (motionless motor).



In order to limit the motor and drive heating there is a function able to automatically reduce the supplied current after a defined time (settable) from the stop of the motor.



The DS10 drives allow to define accurately both the current reduction percentage and the timing from the motor stop to the reduction intervention. The regulation dynamics is extraordinarily wide and allows to change the current between 0% and 100% of the nominal current. The reduction intervention time can be set in few milliseconds up to 10 seconds. Setting a value equal to 0% the current is completely set off when the motor is firm, while setting 100% the current is always maintained at the nominal value.

The current reduction percentage must be set considering the real torque required by the application when the motor is firm, while the second parameter (the time) must be set according to the time that the load takes to stable after the stop of the motor or to the application working cycle.

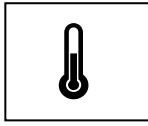

Observe that removing the current reduction with motor at rest (that is to say setting the 100% value) the motor and the drive heat more. It is therefore suggested to make this calibration only if the application requires an high static torque to the motor.

The following figure shows the relation between the pulses applied to the STEP input and the automatic current reduction.

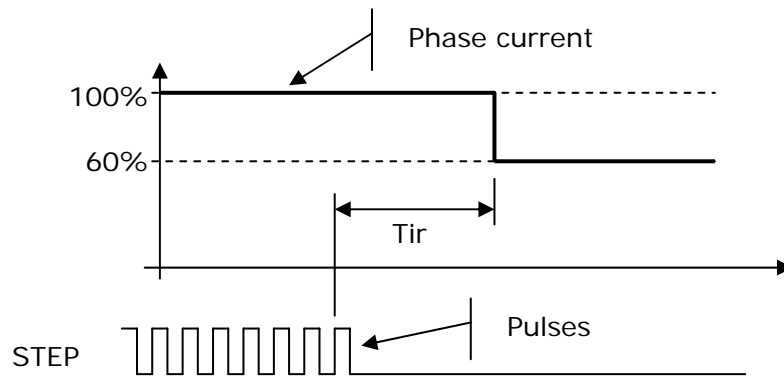

After the last STEP input disable/enable transition the *Tir* time starts to pass, after which the automatic current reduction intervenes reducing the phase current (in the example to the 60% of the nominal value, i.e. of the set configuration value).

The BOOST input allows to manually reduce the current even while motor is rotating. This feature can be useful to reduce the heating when the whole torque supplied by the motor is not required (for example when the load moves at constant speed).



Through the DIRECTION input it is then possible to suspend the automatic current reduction. A commutation from the enable to the disable status sets to zero the timer used for the automatic current reduction intervention. Therefore, changing the DIRECTION input with a time inferior to *Tir* (time set for the automatic current reduction) the reduction never intervenes, maintaining the motor always supplied by the nominal current.

5.2.3 Resolution



The DS10 drives allow to choose among many divisions, both of decimal and binary type, as shown in the following table.

Decimal		Binary	
Step / Rev	Microstep / Step	Step / Rev	Microstep / Step
1000	5	200	1
2000	10	400	2
4000	20	800	4
5000	25	1600	8
10000	50	3200	16
25000	125	6400	32
		12800	64
		25600	128

The step/rev in the table refers to a stepper motor with 1.8° step angle. If the motor used has a different step angle, the step/rev number will be different too. For example, the motor has a 0.9° step angle, the step/rev indicated in the above table must be multiplied by 2.

The resolution choice must be mostly made in accordance with the application requirements taking into consideration that a greater resolution offers also a better positioning precision and minor vibrations at low speed but, on the other side, it requires a greater pulses frequency applied to the STEP input.

Instead, low resolutions allow to obtain high motor rotation speeds, even with modest pulses frequencies applied to the STEP input, but they can generate vibrations and resonance phenomena when the motor works at low speeds. Moreover, the positioning precision is reduced.

In order to correctly evaluate the obtainable precision, it must be considered that, despite the current regulation offered by the drive is accurate, it exists a mechanical error due to the tolerances and to the constructive features of the motor which prevent from appreciating variations inferior to 0.05° .

In the left below figure it is possible to observe the current waveform with a resolution of 800 steps/rev (1/4 step), while the right image shows the current wave form with a resolution of 25600 steps/rev (1/128). In both cases the motor rotates at the same speed.

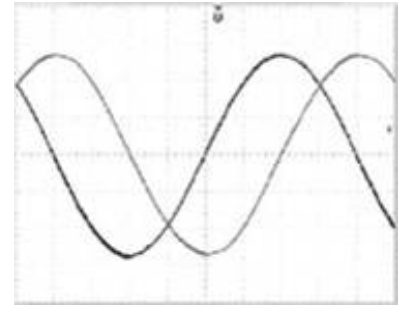
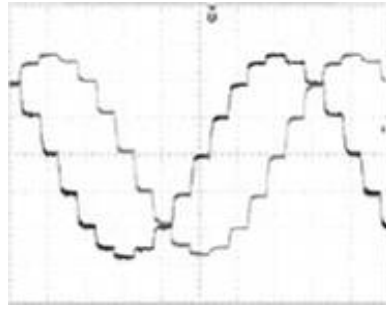

When minor resolution is working (left figure) the motor movement is noisier while when the resolution is greater (right figure) the motor moves smoothly and with less vibrations.

In the above example, in order to maintain the same motor rotation speed, it has been necessary to pass from a pulses frequency applied to the STEP input of 1KHz, relative to a 800 steps/rev resolution (left figure), to 32KHz, required to obtain the same speed with a 25600 steps/rev resolution (right figure).

5.2.4 Current waveform modification



The extraordinary flexibility offered by the DS10 series drive allows to intervene on the current waveform supplied to the motor to better adapt it to the constructive characteristics of the motor itself and of the application. This procedure grants the most rotation homogeneity and the maximum positioning precision.

The parameters on which it is possible to intervene through the *UDP Commander* are the *Shape* and the *Offset*.

Shape

The *Shape* parameter allows to modify the current profile changing the sine/cosine shape normally used.

Offset

The *Offset* parameter adds or deducts a DC component to the current waveform applied to the motor.

5.2.5 Inputs and outputs conditioning



The DS10 series drives apply a simple and flexible configuration of the input and output lines, hardly findable in other products of the same category.

The inputs and the outputs can be enabled, disabled, negate, put always enable or always disable, independently from the real input status and independently one from the other. All this is simply obtained, through the *UDP Commander* configuration software, without the need to recur to hardware interventions on the drive (dip-switch, jumpers, etc.).

The following is the description of the supported operative modes:

Enable

When the input is in this status, the drive interprets normally (in a direct mode) the signal applied to the input.

Disabled

This mode is equivalent to disconnect the input signal from the drive, any input status change is ignored .

Direct

The signal applied to the input is elaborated by the drive in direct mode, without inversion.

Negate

The signal applied to the input is elaborated by the drive in negate mode (reverse). When the input is active the drive works as the input is inactive and vice versa.

Active















The drive elaborates the input as it was always active, independently from its real status. If, for example, the drive must enable autonomously at the start, without the necessity to activate the ENABLE input, it is sufficient, through the configuration, to put that input in the active status.

Inactive



The drive elaborates the input as it was always inactive, independently from its real status. This can be useful to block the rotating direction always in one sense (applying this configuration to the DIRECTION input) or to disable permanently the drive without intervening on the wirings (applying therefore the configuration to the ENABLE input).

In the following table are listed the inputs and outputs with their own possible settings and a graphical representation of how the signal is treated (high level = active input, low level = inactive input).

Input signal	Conditioning type	Signal "seen" by the drive	Available for signals				
			STEP	DIRECTION	ENABLE	BOOST	FAULT
	Enabled		Yes	No	No	No	No
	Disabled		Yes	No	No	No	No
	Direct		No	Yes	Yes	Yes	Yes
	Negate		No	Yes	Yes	Yes	Yes
	Active		No	Yes	Yes	Yes	Yes
	Inactive		No	Yes	Yes	Yes	Yes

5.2.6 Alarms and Protections conditioning

In order to protect the drive and to make easier the identification of the most common functioning or setting anomalies, the DS10 drives are equipped with many alarms and a complete diagnostics.



Furthermore, the extraordinary flexibility offered by the product allows to singularly configure the operative mode of each alarm choosing among *Automatic*, *Permanent*, *Enable* or *Disable*.

The configuration is made without the necessity to intervene on the drive's hardware, without jumper, dip-switch, etc.

Automatic

The drive constantly examines the alarm condition and when this disappears it provides autonomously to remove the signal and to turn back to the operative status.

Permanent

Each alarm condition remains in the drive's memory. To remove the signal the drive must be switched off and then switched on again.

Enable

The alarm condition signal remains till the drive is not disabled through the ENABLE input.

Disable

The alarms are disabled and ignored by the drive. For security reasons some protections cannot be put in this status.

In the following table are resumed the various possible settings for each single alarm.

Alarm type / protection	Possible setting			
	Automatic	Permanent	Enable	Disable
Under voltage	Yes	Yes	Yes	No
Over voltage	Yes	Yes	Yes	No
Over temperature	Yes	Yes	Yes	No
Phase-to-phase short circuit	Yes	Yes	Yes	No
Phase-to-ground short circuit (GND)	Yes	Yes	Yes	No
Phase-Vp short circuit	Yes	Yes	Yes	No
Interrupted Phase A	Yes	Yes	Yes	Yes
Interrupted Phase B	Yes	Yes	Yes	Yes

For a complete description of protections and alarms see chapter 5.5 Prote.

5.3 Inputs and outputs

5.3.1 General description



The DS10 drives have signal inputs and outputs which can be used in NPN or PNP logics.

Each input presents both connections allowing also mixed configurations. All the inputs and outputs are optocoupled, among them, towards the motor and towards the power supply. Moreover, the working voltage levels allow the inputs line driving.

5.3.2 Inputs

In the following explanation it is assumed that the real status of input signals is the same seen by the drive. In other words, during the configuration no signal conditioning must have been made (*Direct or Enable* setting).

STEP

This input is used to command the motor rotation. Any time the input goes from the inactive to the active status the motor makes an angle step as defined by the resolution setting (see chapter 5.2.3 Resolution). The effective rotation direction (clockwise or counter-clockwise) depends on the DIRECTION input status and on the connection between the motor phases and the drive (inverting the phase FA+ with FA- or the phase FB+ with FB-, the motor rotates oppositely).

Any pulse applied to the STEP input sets to zero the timer counting associated to the automatic current reduction.

With the automatic current reduction active, a new pulse applied to the STEP input restores the current to the nominal value again.

DIRECTION

This input is used to reverse the motor rotation direction. When the input is active the motor moves in the direction opposite to the one obtained with the inactive set input. The effective rotation direction, clockwise or counter-clockwise, cannot be prior determined as it depends on the connection sequence between the drive and the motor.

The DIRECTION input has another important function; if the motor phase current is reduced due to the automatic current reduction (see chapter 5.2.2 Automatic current reduction) a change of the DIRECTION input status forces again the current to the nominal value.



This original feature allows to avoid the automatic current reduction to intervene simply changing the DIRECTION input status in a sufficiently quick way to avoid the same automatic current reduction to occur (i.e. in a time inferior to the one set for the *Tir* parameter).

It is possible to use this technique also to restore the current to the nominal value in advance respect to the first pulse applied to the STEP input.

Through the configuration it is possible to condition this signal to better adapt it to the application (see chapter 5.2.5 Inputs and outputs conditioning).

ENABLE

This input is used to enable the drive. When the input is active the drive is enabled and supplies current to the motor; on the contrary when the input is inactive the motor current is null.

ATTENTION, do not use the ENABLE input to put the application in security. The only way to be sure the motor is not supplied is to remove the supply from the drive and wait for at least 30 seconds.

Setting the ENABLE input as inactive, the signaling of the no more active alarms configured as *Enable* is removed (for more details see chapter **Errore. L'origine riferimento non è stata trovata. Errore. L'origine riferimento non è stata trovata.**).

Through the configuration it is possible to condition this signal to better adapt it to the application (see chapter 5.2.5 Inputs and outputs conditioning).

BOOST

This input is used for the boost functionality or manual current reduction. The BOOST input allows to over supply the motor to obtain greater torque (required for example to win inertial forces) or, on the contrary, to reduce the phase current if not totally necessary (in order to contain the drive and motor heating). When the input is inactive, to the motor is applied the nominal phase current while if the input is active the current is reduced by the percentage defined by the configuration (see chapter 5.2.2 Automatic current reduction).

To realize the over supply function it is necessary to maintain the BOOST input active and set the drive in order that the set nominal current, reduced by the percentage indicated by the *Vir* parameter, is equivalent to the phase current required by the normal functioning. Bringing then the input to the inactive status the current will reach the setting nominal value, over supplying the motor by a percentage pair to the difference between 100% and the *Vir* parameter value (for example, if *Vir* is set for the 75% the phase current will be increased by 25%, $100\% - 75\% = 25\%$).

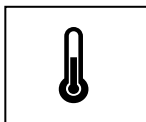

When the application does not need continuously the maximum motor torque, it is possible to use the BOOST input to reduce the phase current and consequently the heat dissipated on the drive and on the motor. To obtain the maximum torque the BOOST input must be left inactive, on the contrary when a smaller torque is sufficient to be put the BOOST input in the active status.

The operating logics above described can be easily inverted by conditioning the signal given by the configuration (see chapter 5.2.5 Inputs and outputs conditioning).

5.3.3 Outputs

In the following explanation of the single output signals it is assumed that during setting no signal conditioning has been made:

Fault

When the drive is in the operating status the output is active (closed), on the contrary when there is the signaling of one or more alarms the output is inactive (open).

Through the configuration it is possible to condition this signal to invert its logic and to adapt it to the application (see chapter 5.2.5 Inputs and outputs conditioning).

5.3.4 Timing relations among control signals

The input signals must observe some exact temporal relations to assure the correct drive functioning. If such relations are not respected the drive is not damaged but it can produce unexpected results and position loss of the motor.

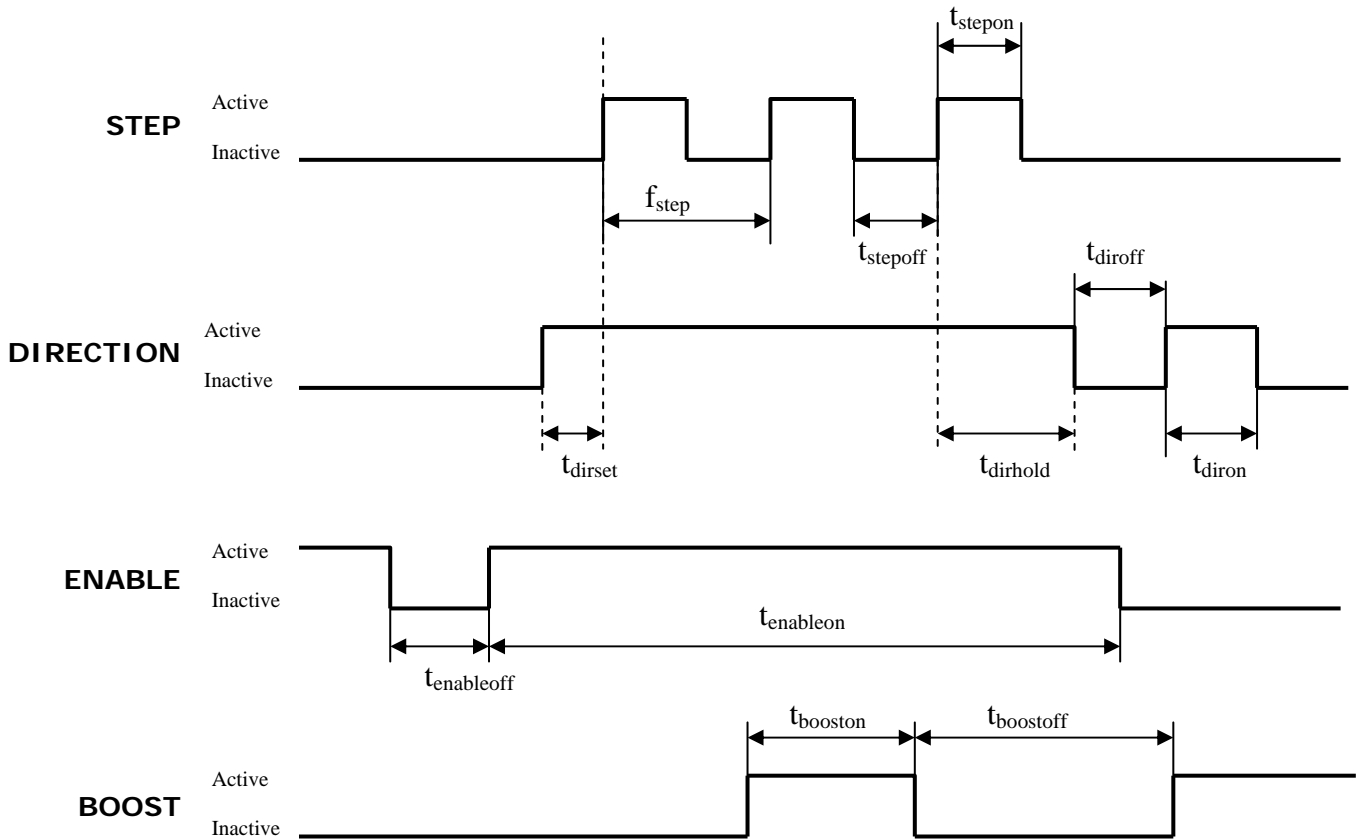

Symbol	Description	Value			Unit
		Min	Typ	Max	
f_{step}	Step frequency (equivalent step/rev)			6000	rpm
t_{stepon}	Active STEP input timing	1.3			μ sec
$t_{stepoff}$	Inactive STEP input timing	2			μ sec
t_{dirset}	DIRECTION signal setting in respect to STEP	16			μ sec
$t_{dirhold}$	DIRECTION signal maintaining in respect to STEP	16			μ sec
t_{diron}	Active DIRECTION input timing	300			μ sec
t_{diroff}	Inactive DIRECTION input timing	300			μ sec
$t_{enableon}$	Active ENABLE input timing	300			μ sec
$t_{enableoff}$	Inactive ENABLE input timing	300			μ sec
$t_{booston}$	Active BOOST input timing	300			μ sec
$t_{boostoff}$	Inactive BOOST input timing	300			μ sec

5.4 Signal LEDs

The drive has three signal LEDs: the green one called *On*, the yellow LED called *Enable / Step* and the red one called *Fault*.

On

The LED called *On* lights up when the drive is supplied with a voltage sufficient to allow a correct functioning of the control electronics. When the LED is on, the drive is able to elaborate the information but it is not necessarily in the working status (because, for examples, the supply voltage is beyond the working limits or the temperature is excessive).

Enable / Step

This LED supplies contemporaneously various information about the status of the drive and the signal inputs. When the ENABLE input is active the LED is fixed lighted up, when the input is inactive the LED is off. When pulses reach the STEP input the LED status inverts for an instant. In other words, in presence of pulses to the STEP input and with the ENABLE input active, the LED is mostly lighted up with short switching off; while with the ENABLE input inactive and pulses to the STEP input, the LED remains mostly off with short lighting flashes. The LED inverts its condition for an instant even in presence of a status change of the DIRECTION input.



This original working method allows an immediate wiring diagnostics and also points out eventual electric noises. In this case, in fact, there will be a yellow LED's flashing even when the control equipment (PC or others) is not active. The drive features grant at least a LED lighting flash in presence of pulses on the STEP input or transitions on the DIRECTION input. However, bear in mind that, if the events are too close, part of the successive events could not be visualized.

Relation between the yellow LED and the ENABLE, STEP and DIRECTION inputs		
STEP / DIRECTION	ENABLE	Yellow LED status
Inactive / No status change	Inactive	On Off
Inactive / No status change	Active	On Off
Pulses / Status change	Inactive	On Off
Pulses / Status change	Active	On Off

Fault

This LED lights up each time there is at least an alarm signaling. When the LED is lighted up, the drive is not operative and the motor is without supply (observe that also in this condition the yellow LED continues its own activity as described in the previous chapter).



In presence of an alarm the red LED lights up and starts a sequence of flashing related to the kind of problem found. The following table shows the association between the number of flashes and the error found.

Codification of errors signaled by red LED	
Number of flashes	Problem description
1	Under voltage, the supply voltage is inferior to V_{pl} value
2	Over voltage, the supply voltage is superior to V_{ph} value
3	Over temperature, the heat sink temperature is superior to T_{chh}
4	Phase-to-phase short circuit, one or two phases are in short circuit
5	Phase-to-ground short circuit (GND), phase in short circuit with ground
6	Phase- V_p short circuit, one phase is in short circuit with power supply
7	Interrupted phase A, connection between drive and motor is missing
8	Interrupted phase B, connection between drive and motor is missing

If more than a problem occurs contemporaneously the lighting flashes sequences associated to each one of them are cyclically executed. If, for example, the over temperature condition occurs together with the over voltage one, the LED will flash twice and then three times alternatively till when the malfunction signaling will be removed.

The drive features grant at least a visualization cycle for each activated alarm. For this reason it is not possible to remove an alarm before the first visualization cycle is finished.

Observe that each error signals can be removed in different ways according to how the drive's configuration has been made (for a close examination see chapter 5.2.6 Alarms and Protections conditioning).

For a detailed description on the various alarms and protections see chapter 5.5 Protections.

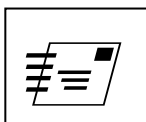

When in the drive the *Loader* (an always resident small software necessary for the firmware update) is active, the *Fault* LED remains always on. To restore the normal functioning it is sufficient to load a compatible firmware in the drive.

5.5 Protections

5.5.1 General description

The drive is equipped with efficient protections which protect its integrity whenever one of the most common problems occurs. Furthermore, some controls have been implemented which can detect positioning errors even before the motor starts to move.

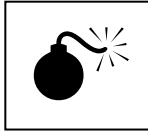

In spite of the care and attention used in the development and manufacturing of the drive, an installation or an use not in compliance with the indications present in this manual, or out of stated maximum limits, can damage the drive permanently.



Through the configuration it is possible to define the drive behavior at the occurring of the various alarm conditions. For example, it is possible to choose and make permanent an alarm or to set the drive so that it is automatically re-enabled as soon the alarm condition is ceased. For a detailed description about the various configuration options see chapter 5.2.6 Alarms and Protections conditioning.

When there is at least an alarm signal the drive is not active and the motor is not supplied, consequently the torque is null.

5.5.2 Under voltage

The under voltage alarm intervenes when the drive supply voltage is inferior to the V_{pl} value (V_{acl} for the AC models). Such value varies according to the drive model as per the following table.

Model	Vpl value (Vacl)			Unit
	Min	Typ	Max	
DS1041		18		Vdc
DS1044		20		
DS1048		20		
DS1073		24		
DS1076		24		
DS1078		24		
DS1084		45		
DS1087		45		
DS1098		45		
DS1041A		13.5		Vac
DS1044A		15		
DS1048A		15		
DS1073A		18		
DS1076A		18		
DS1078A		18		
DS1084A		33		
DS1087A		33		

The drive constantly verifies the supply voltage value; it is sufficient that it goes beyond the V_{pl} threshold (V_{acl} for the AC models) for few instants to generate the under voltage alarm. It does not have to be astonishing the fact that the protection intervenes despite the measured voltage is within the functioning limits, as it is possible that, because of the main supply fluctuations or cables length, the voltage that effectively reaches the drive becomes, in particular moments (for example during the motor acceleration phase), inferior to V_{pl} value (V_{acl} for AC models).

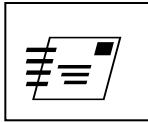

In order to make a correct measurement it is necessary to act directly on the drive supply terminal blocks, using a band-pass instrument of at least 10KHz (as an oscilloscope, for example) able to memorize the voltage transients minimum values.

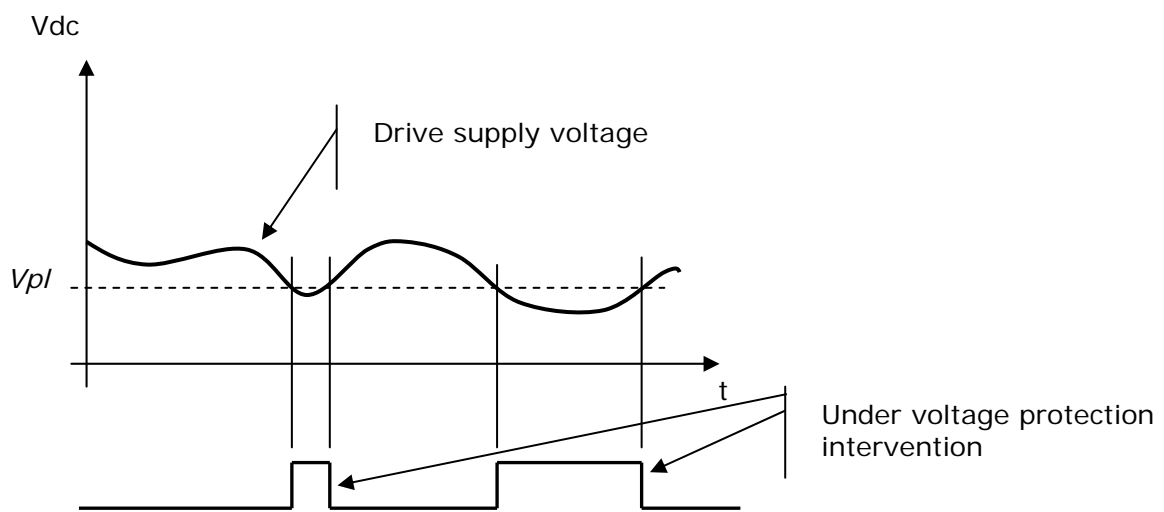

If the supply voltage is very near to the drive functioning limit and sporadically the under voltage alarm intervenes, it is possible, in some cases, to solve the problem reducing the distance between the power supply and the drive, increasing the cables section or placing an electrolytic capacitor near the drive itself (valid only the DC models).

5.5.3 Over voltage

The over voltage protection intervenes when the supply voltage is superior to the V_{ph} value (V_{ach} for the AC models). In these conditions the drive protects the power stage turning it off. Such value varies according to the drive model, as per the following table.

Model	Vph value (Vach)			Unit
	Min	Typ	Max	
DS1041		50		Vdc
DS1044		55		
DS1048		55		
DS1073		98		
DS1076		98		
DS1078		98		
DS1084		175		
DS1087		175		
DS1098		248		
DS1041A		37		
DS1044A		40		
DS1048A		40		
DS1073A		71		
DS1076A		71		
DS1078A		71		
DS1084A		124		
DS1087A		124		

The drive constantly controls the supply voltage and when it goes beyond the *Vph* value (*Vach* for AC models), even also for few instants, the over voltage protection intervenes.

It does not have to be astonishing the fact that the protection intervenes despite the measured voltage is within drive functioning limits. In fact it is possible that, in some occasions (sudden motor decelerations, sudden voltage changes, etc.) the voltage which supplies the drive goes beyond the *Vph* value (*Vach* for AC models) causing the protection intervention.

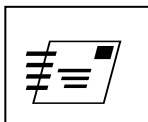

In order to make a correct measurement of the effective drive supply voltage it is necessary to act directly on the supply terminal blocks of the drive itself, using a band-pass instrument of at least 10KHz and able to capture the voltage transients peaks.

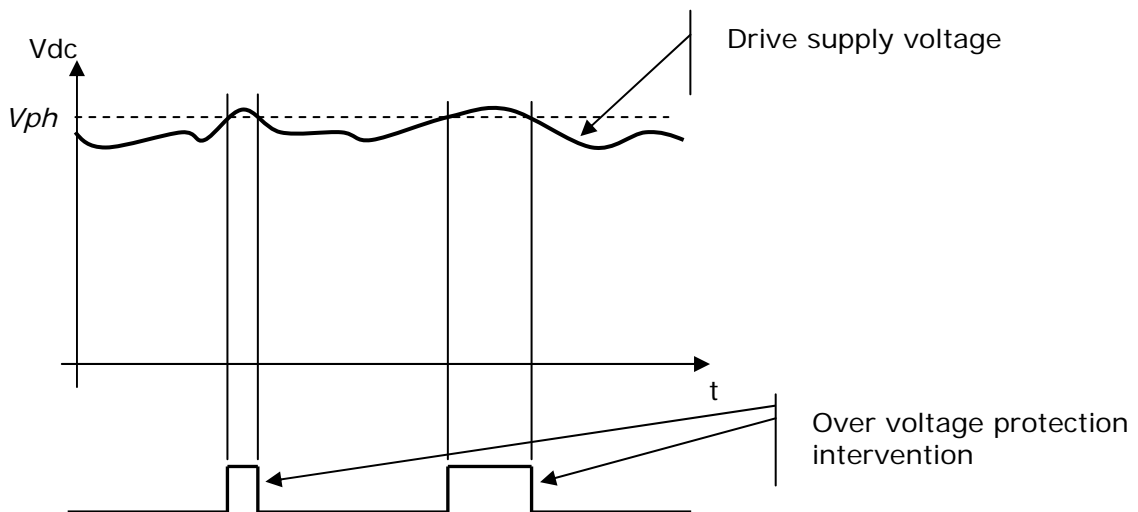

If the supply voltage is very near to the drive functioning limit and the over voltage alarm sporadically intervenes, it is possible in some cases to solve the problem reducing the distance between the power supply and the drive, increasing the cables section or placing an electrolytic capacitor near the drive (valid only for DC models).

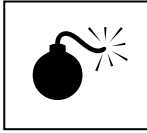

ATTENTION, if the supply voltage increases a lot beyond the maximum functioning value, and in particular it goes beyond the V_{pbrk} breakdown voltage (V_{acbrk} for AC models), the drive will be irreversibly damaged.

When the over voltage protection intervenes because of the energy returned from the motor during the deceleration phase, which causes a bus voltage rise beyond the V_{ph} value (V_{ach} for AC models), it is possible to avoid such condition using a braking resistor calibrated to intervene before the bus voltage reaches the V_{ph} value (V_{ach} for AC models).

The power supplies of the DP1xx2 series integrate this functionality and represent a valid solution to solve this problem.

5.5.4 Over temperature

The over temperature protection intervenes when the drive power stage temperature goes beyond the T_{chh} value. In this condition the drive stops working.

This intervention ends when the temperature falls below T_{chl} value. When this occurs the alarm signal is removed or not according to the drive configuration (see chapter 5.2.6 Alarms and Protections conditioning)

Symbol	Description	Value			Unit
		Min	Typ	Max	
Tchh	Intervention threshold of thermal protection	85	90	95	°C
Tchl	Restoration threshold of thermal protection	60	65	70	°C

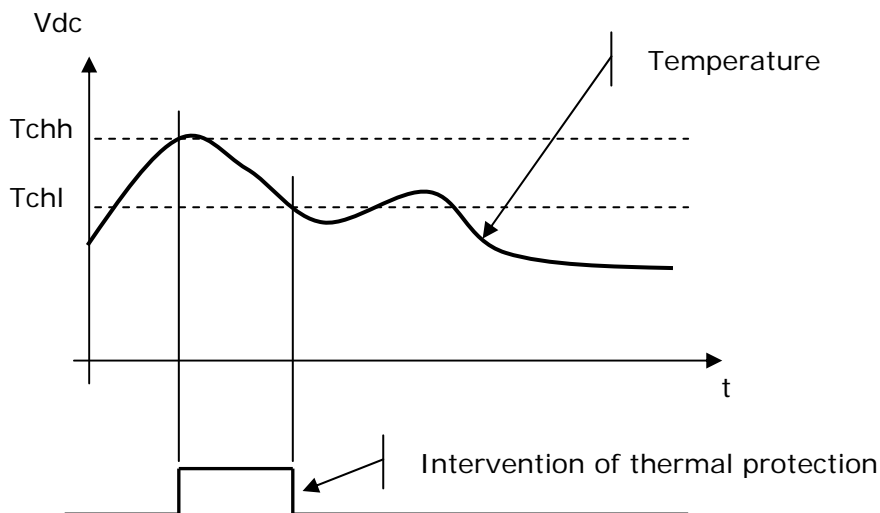

5.5.5 Phase-to-phase short circuit

In case of a motor wirings short circuit, on the same phase or on different phases (cross phase short circuit), the drive stops working and activates the phase-to-phase short circuit protection.

This kind of protection requires a careful survey to find the cause of the short circuit. Consider that the short circuit can be, apart in the wiring, also inside the motor.

According to the drive configuration (see chapter 5.2.6 Alarms and Protections conditioning) the protection can be removed through a turning off and on cycle or disabling temporarily the drive through the ENABLE signal.

5.5.6 Phase-to-ground short circuit

The protection starts whenever one of the connections towards the motor creates a short circuit with the drive ground connection (GND). In these conditions the drive protects itself switching off the supply to the motor and putting itself in an inactive status.

This intervention of this protection requires a careful survey to find the cause of the short circuit. Consider that the short circuit can be, apart in the wiring, also inside the motor.

According to the drive configuration (see chapter 5.2.6 Alarms and Protections conditioning) the protection can be removed through a turning off and on cycle or disabling temporarily the drive through the ENABLE signal.

5.5.7 Phase-to-Vp short circuit (Vac)

Whenever one of the phase connections (motor connections) cause a short circuit with the supply voltage positive (+Vp or Vac for the AC models) the phase-to-Vp short circuit protection starts. When this condition occurs the drive protects itself switching off the supply to the motor and putting itself in an inactive status.

According to the drive configuration (see chapter 5.2.6 Alarms and Protections conditioning) the protection can be removed through a turning off and on cycle or disabling temporarily the drive through the ENABLE signal.

5.5.8 Interrupted phase A, interrupted phase B



If the connection between the drive and the motor is interrupted, even if of only a single phase, or an inner motor winding is damaged (interrupting itself), the drive activates the interrupted phase alarm. For a more accurate diagnostics the signal is distinguished for the phase A and phase B.

Take present that the drive executes the interrupted phase control only with the drive enabled and with the motor at rest or with rotation speed inferior to 15rpm (independently by the set resolution).

5.6 Advanced functionalities

5.6.1 General description



The innovative hardware structure of the drive allows to integrate advanced functionalities compared to the common step and direction drives, without penalizing the product cost and size.

This manual describes the functions present in the firmware revision indicated on the cover. Subsequent revisions could integrate further functions and it is therefore advisable to always verify to have the last manual edition visiting the www.lamtechnologies.com.

The available advanced functionalities are *Gate* and *Oscillator*.

5.6.2 Gate

The *Gate* function allows to enable or not the execution of the pulses applied to the STEP input through a GATE control signal.



This feature makes possible the use of a single step source to control more drives when contemporary movements are not required, as shown in the below representation.

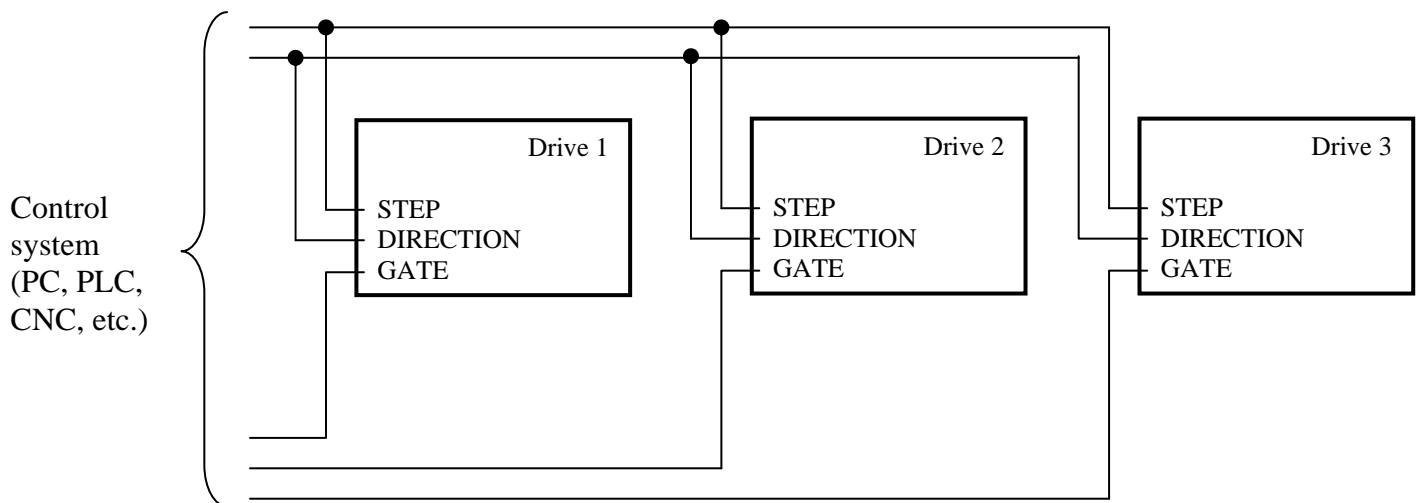

In this case the control system sends a step and direction signal to all the drives contemporaneously, while the GATE signal is activate from time to time on the only drive the control system wants to move. The drives with the GATE signal not activate ignore the pulses and maintain the motor firm.

5.6.2.1 Configuration

To make the *Gate* operating it is necessary to select in the *UDP Commander* software the option button marked *Gate*.

Then it is necessary to define the input to be used as GATE to enable the execution of the pulses applied to the STEP input by the drive. The selection is made through the drop-down list.

Defined the input to be used as GATE, it is possible to intervene through the signal conditioning (drop-down list on the right of the previous one) to adapt it to the logic level used by the control system.

Take present that when the GATE input is active the drive executes the pulses applied to the STEP input, while with the GATE input inactive the signals applied to the STEP input are ignored.

It is important to note that the signal defined as GATE continues to carry out its natural function therefore, if for example the ENABLE input is used as GATE, it will be essential to condition the *Enable* signal “seen” by the drive as *Active* (through the drop-down list on the *Control signals* panel inside *Drive configuration*) so that the drive remains always enable whichever is the logic level assumed by the ENABLE input which carries out the GATE function.

If, as a further example, the BOOST input is used as GATE, it would be better to set the *Boost* signal “seen” by the drive as *Inactive* (through the drop-down list on the *Control signals* panel inside *Drive configuration*). This to avoid that the status change of the BOOST input also generates an alteration of the current supplied to the motor (for more details on the natural functionality of the BOOST input see chapter 5.3.2 Inputs).

5.6.2.2 Time relations among control signals

In the following graph it is shown the relation among the GATE input status, the pulses applied to the STEP input and the steps really executed by the drive.

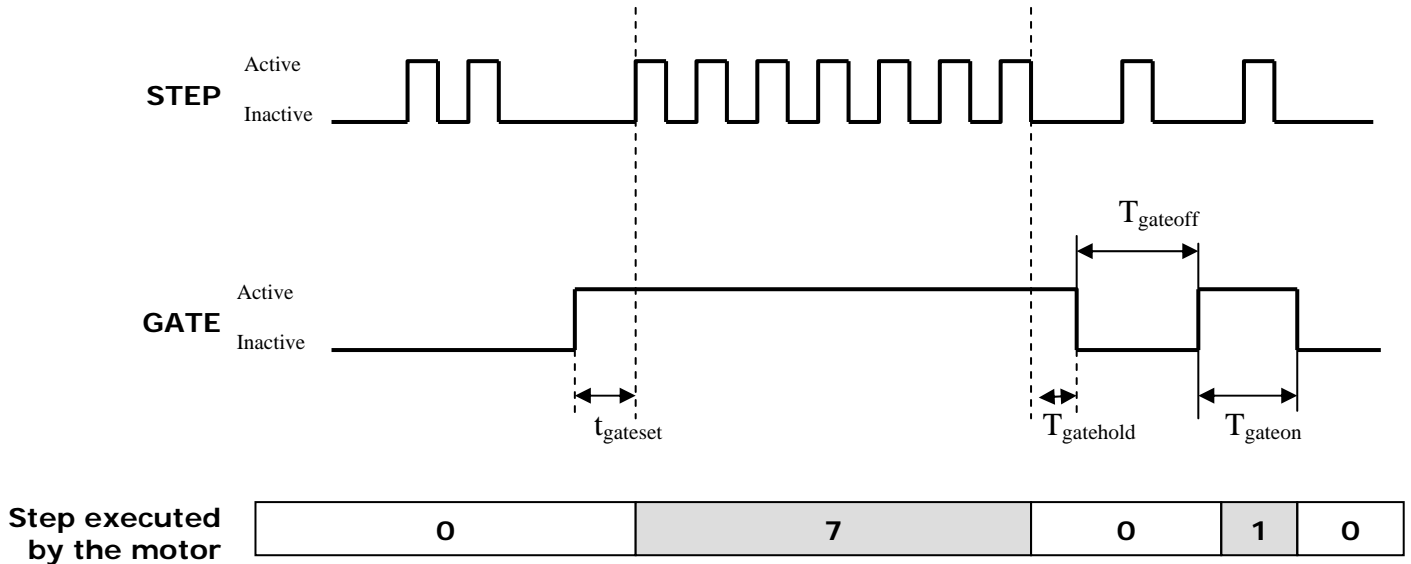

To grant a correct execution of the given commands it is necessary to respect some time relations amongst the signals. In the following table are detailed the limits to be observed.

Symbol	Description	Value			Unit
		Min	Typ	Max	
$T_{gateset}$	GATE signal setting in respect to STEP	200			μsec
$T_{gatehold}$	GATE signal holding in respect to STEP	200			μsec
T_{gateon}	Active GATE input time	500			μsec
$T_{gateoff}$	Inactive GATE input time	500			μsec

5.6.3 Oscillator

The *Oscillator* function allows to command the motor movement through a *start/stop* signal rather than through the pulses normally applied to the STEP input.

This function is particularly useful when there is not the possibility to generate step pulses or when there is a feedback (a sensor or other, for example) which supplies a feedback about the position reached by the motor or on the result obtained by the same (for example a register control).



The *Oscillator* function uses up to two inputs. A first input is used to command the motor start and stop (START/STOP input), while a second input can be configured to select the motor rotation speed between two available ones (SELECT input).

5.6.3.1 Configuration

To make the *Oscillator* function operating it is necessary to select in the *UDP Commander* software the option button marked *Oscillator*.

Then it is possible to choose the input to be used as START/STOP signal and to define the SELECT input for the frequency selection, using the corresponding drop-down list.

For each signal it is then possible to set the digital conditioning to adapt its behavior to the control system logic levels.

The motor rotation occurs when the START/STOP input is active (and the motor is enabled). Instead, with the START/STOP input inactive the drive works in a standard way and the motor rotation is commanded through the STEP input.



This original feature allows, for example, to use the oscillator for gross movements and to use then the STEP input to execute the fine position adjustment.

The motor rotation speed depends on the frequency set in the oscillator function and on the resolution set on the *Drive configuration* panel.

To know the steps/min completed by a 200steps/rev motor it is possible to apply the following formula:

$$\text{rpm} = 60 * \text{Fosc} / \text{stprev}$$

where: rpm = steps/min completed by the motor
 Fosc = frequency set in the oscillator function
 stprev = steps/rev set

For example, if we have set a resolution equal to 1/16 step, a frequency of 800Hz and we use a 200 steps/rev motor, we will obtain a motor rotation speed equal to 15 steps/min. Applying the formula we will obtain:

$$\text{rpm} = 60 * 800 / 3200 = 15$$

The drive does not execute acceleration and deceleration ramps, it is therefore necessary to pay attention to the configuration parameters choice to avoid that a too high rotation speed generates the start stall or the loss of steps at the motor stop.

The maximum speed at which it is possible to start and to stop the motor in absence of ramp depends on many factors, among which the motor torque (which depends on the phase current), the rotor inertia, the load inertia, the frictions, etc.

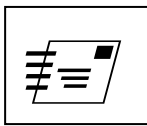

The maximum value can be determined provisionally starting from a low rotation speed to then increase it till when the loss of step is detected. Obtained this value, it is suggested to apply a security coefficient equal to 0.7 (using then a maximum speed decreased by 30%).



In the *Oscillator* function it is possible to set up to two different frequencies (which produce two different rotation speeds) which can be selected in real time, also during the motor rotation, through the SELECT input. This function allows to realize a simple two-steps ramp.

The *Frequency 1* is selected when the SELECT input is inactive, while the *Frequency 2* becomes operative when the SELECT input is active.

Take into account that the signals chosen for the START/STOP and SELECT tasks continue to carry out also their own natural function, therefore not to incur in unexpected behaviors it is essential to condition the signal through the corresponding drop-down list on the *Control signals* panel inside *Drive configuration*.

If, for example, the DIRECTION input is chosen to carry out the SELECT function (for instance because the rotation direction reverse is not necessary), it is essential to set the *Direction* signal as *Active* or *Inactive* on the *Drive configuration* panel to avoid that the change of the input logic level produces the motor direction reverse.

5.6.3.2 Time relations among control signals

In the following graph it is shown the relation among the STEP input, the status of the START/STOP and SELECT inputs, and the motor.

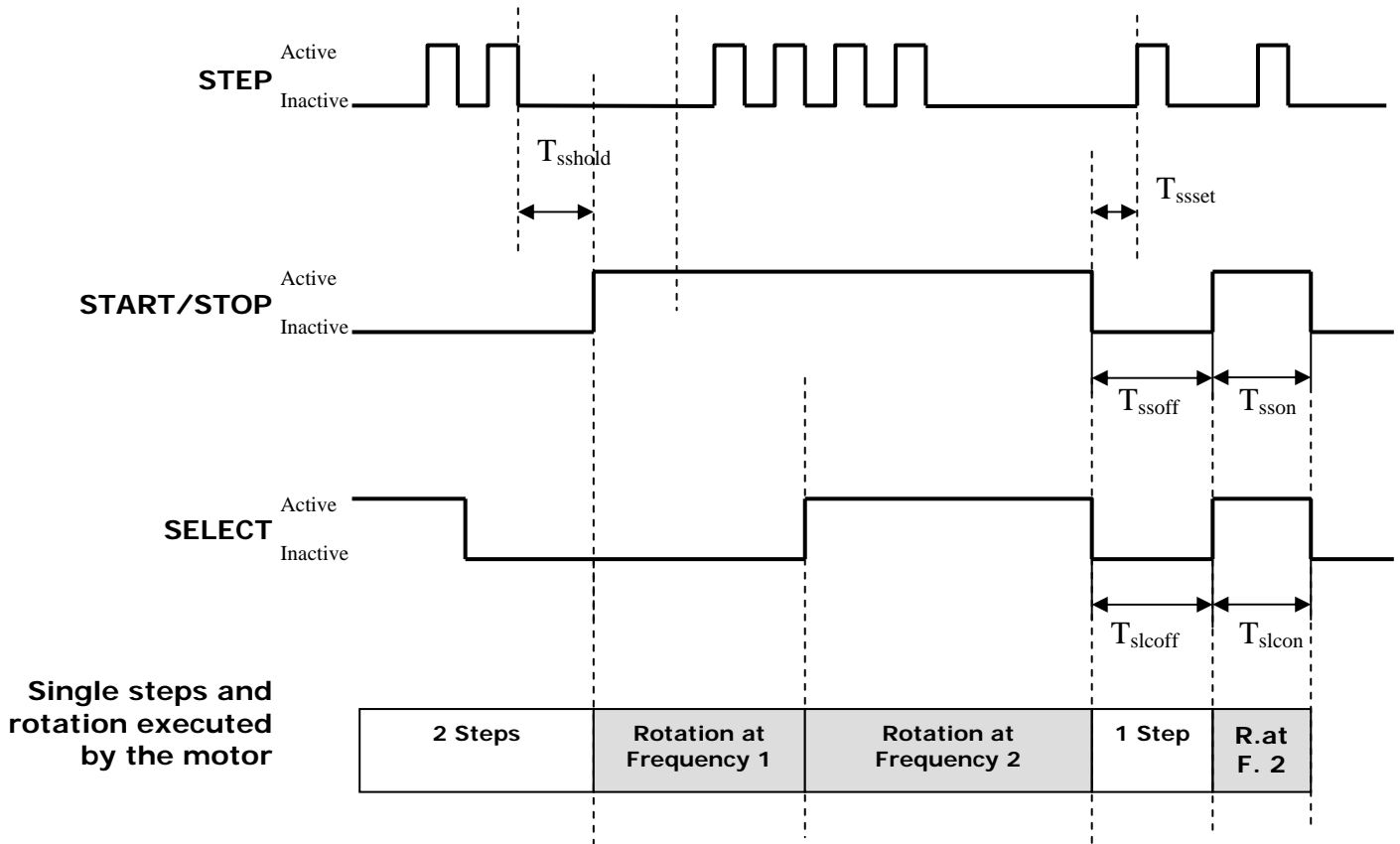

To grant a correct execution of the given commands it is necessary to respect some time relations among the signals. In the following table are detailed the limits to be observed.

Symbol	Description	Value			Unit
		Min	Typ	Max	
T_{ssset}	START/STOP signal setting in respect to STEP	200			μsec
T_{sshold}	START/STOP signal holding in respect to STEP	200			μsec
T_{sson}	Active START/STOP input time	500			μsec
T_{ssoff}	Inactive START/STOP input time	500			μsec
T_{slcon}	Active SELECT input time	500			μsec
T_{slcoff}	Inactive SELECT input time	500			μsec

6 Technical data

The electric, physical and mechanical details of each single drive are reported below.

DS1041A					
Symbol	Description	Value			Unit
		Min	Typ	Max	
Vac	Power supply AC voltage	16		36	Vac
If	Motor phase current (rms)	0.3		1,4	Arms
Vir	Automatic current reduction	0		100	%
Tir	Current reduction intervention time	0.05		10	s
Vacbrk	Permanent breakdown voltage			42	Vac
Vach	Over voltage protection intervention	36.5		39	Vac
Vacl	Under voltage protection intervention	12.5		14.5	Vac
Tchh	Thermal protection intervention threshold	82	86	94	°C
Tchl	Thermal protection restoration threshold	60	62	66	°C
Plss	Power lost on the drive			7	W
Res	Step resolution available	200, 400, 800, 1000, 1600, 2000, 3200, 4000, 5000, 6400, 10000, 12800, 25000, 25600			Step / Rev.
MI	Motor inductance seen by the drive	0.8		50	mH
Vdi	Digital input voltage range	3		28	Vdc
Vdibrk	Digital input breakdown voltage	-30		+30	Vdc
Idi	Digital input supply current	4	6	8	mA
Vdo	Digital output voltage range	1		30	Vdc
Vdobrk	Digital output breakdown voltage	-0.5		37	Vdc
Vdoz	Output zener diode voltage	37	39	42	Vdc
Ido	Digital output current range			60	mA
Idobrk	Digital output breakdown current	120			mA
Pwdo	Digital output dissipable power			400	mW
Fch	Chopper frequency		20		KHz
Prt	Protections / Diagnostics / Alarms	Over/Under voltage, Short circuit Overheating, Break phase			
Mechanical Specifications					
FDh	Height		100.4		mm
FDI	Depth		119.0		mm
FDw	Width		22.5		mm
FDnw	Weight		190		g
Rated range of use					
FCa	Altitude			2000	m
Idr	If current degrading every 1000m beyond the FCa altitude value		5		%
FCt	Temperature	0		50	°C
FCh	Humidity (no condensing)	5		90	%
Conditions of storage and transport					
SCa	Altitude			4000	m
SCt	Temperature	-20		70	°C
SCh	Humidity (no condensing)	5		95	%

DS1041					
Symbol	Description	Value			Unit
		Min	Typ	Max	
Vp	Power supply DC voltage	18		50	Vdc
If	Motor phase current (rms)	0.3		1,4	Arms
Vir	Automatic current reduction	0		100	%
Tir	Current reduction intervention time	0.05		10	s
Vprp	Allowed ripple (100Hz)			8	Vpp
Vpbrk	Permanent breakdown voltage	-0.5		56	Vdc
Vph	Over voltage protection intervention	50.2		51.5	Vdc
Vpl	Under voltage protection intervention	16.0		17.8	Vdc
Tchh	Thermal protection intervention threshold	82	86	94	°C
Tchl	Thermal protection restoration threshold	60	62	66	°C
Plss	Power lost on the drive			5	W
Res	Step resolution available	200, 400, 800, 1000, 1600, 2000, 3200, 4000, 5000, 6400, 10000, 12800, 25000, 25600			Step / Rev.
MI	Motor inductance seen by the drive	0.8		50	mH
Vdi	Digital input voltage range	3		28	Vdc
Vdibrk	Digital input breakdown voltage	-30		+30	Vdc
Idi	Digital input supply current	4	6	8	mA
Vdo	Digital output voltage range	1		30	Vdc
Vdobrk	Digital output breakdown voltage	-0.5		37	Vdc
Vdoz	Output zener diode voltage	37	39	42	Vdc
Ido	Digital output current range			60	mA
Idobrk	Digital output breakdown current	120			mA
Pwdo	Digital output dissipable power			300	mW
Fch	Chopper frequency		20		KHz
Prt	Protections / Diagnostics / Alarms	Over/Under voltage, Short circuit Overheating, Break phase			
Mechanical Specifications					
FDh	Height		100.4		mm
FDI	Depth		119.0		mm
FDw	Width		17.5		mm
FDnw	Weight		160		g
Rated range of use					
FCa	Altitude			2000	m
Idr	If current degrading every 1000m beyond the FCa altitude value		5		%
FCt	Temperature	0		50	°C
FCh	Humidity (no condensing)	5		90	%
Conditions of storage and transport					
SCa	Altitude			4000	m
SCt	Temperature	-20		70	°C
SCh	Humidity (no condensing)	5		95	%

DS1044A					
Symbol	Description	Value			Unit
		Min	Typ	Max	
Vac	Power supply AC voltage	18		36	Vac
If	Motor phase current (rms)	1		4	Arms
Vir	Automatic current reduction	0		100	%
Tir	Current reduction intervention time	0.05		10	s
Vacbrk	Permanent breakdown voltage			42	Vac
Vach	Over voltage protection intervention	36.5		39	Vac
Vacl	Under voltage protection intervention	12.5		14.5	Vac
Tchh	Thermal protection intervention threshold	85	90	95	°C
Tchl	Thermal protection restoration threshold	60	65	70	°C
Plss	Power lost on the drive			12	W
Res	Step resolution available	200, 400, 800, 1000, 1600, 2000, 3200, 4000, 5000, 6400, 10000, 12800, 25000, 25600			Step / Rev.
MI	Motor inductance seen by the drive	0.8		50	mH
Vdi	Digital input voltage range	3		28	Vdc
Vdibrk	Digital input breakdown voltage	-30		+30	Vdc
Idi	Digital input supply current	4	6	8	mA
Vdo	Digital output voltage range	1		30	Vdc
Vdobrk	Digital output breakdown voltage	-0.5		37	Vdc
Vdoz	Output zener diode voltage	37	39	42	Vdc
Ido	Digital output current range			60	mA
Idobrk	Digital output breakdown current	120			mA
Pwdo	Digital output dissipable power			300	mW
Fch	Chopper frequency		20		KHz
Prt	Protections / Diagnostics / Alarms	Over/Under voltage, Short circuit Overheating, Break phase			
Mechanical Specifications					
FDh	Height	100.4			mm
FDI	Depth	119.0			mm
FDw	Width	35.0			mm
FDnw	Weight	190			g
Rated range of use					
FCa	Altitude			2000	m
Idr	<i>If</i> current degrading every 1000m beyond the <i>FCa</i> altitude value		5		%
FCt	Temperature	0		50	°C
FCh	Humidity (no condensing)	5		90	%
Conditions of storage and transport					
SCa	Altitude			4000	m
SCt	Temperature	-20		70	°C
SCh	Humidity (no condensing)	5		95	%

DS1044					
Symbol	Description	Value			Unit
		Min	Typ	Max	
Vp	Power supply DC voltage	20		50	Vdc
If	Motor phase current (rms)	1		4	Arms
Vir	Automatic current reduction	0		100	%
Tir	Current reduction intervention time	0.05		10	s
Vprp	Allowed ripple (100Hz)			8	Vpp
Vpbrk	Permanent breakdown voltage	-0.5		60	Vdc
Vph	Over voltage protection intervention	56.0		57.5	Vdc
Vpl	Under voltage protection intervention	18.5		19.7	Vdc
Tchh	Thermal protection intervention threshold	85	90	95	°C
Tchl	Thermal protection restoration threshold	60	65	70	°C
Plss	Power lost on the drive			8	W
Res	Step resolution available	200, 400, 800, 1000, 1600, 2000, 3200, 4000, 5000, 6400, 10000, 12800, 25000, 25600			Step / Rev.
MI	Motor inductance seen by the drive	0.8		50	mH
Vdi	Digital input voltage range	3		28	Vdc
Vdibrk	Digital input breakdown voltage	-30		+30	Vdc
Idi	Digital input supply current	4	6	8	mA
Vdo	Digital output voltage range	1		30	Vdc
Vdobrk	Digital output breakdown voltage	-0.5		37	Vdc
Vdoz	Output zener diode voltage	37	39	42	Vdc
Ido	Digital output current range			50	mA
Idobrk	Digital output breakdown current	120			mA
Pwdo	Digital output dissipable power			300	mW
Fch	Chopper frequency		20		KHz
Prt	Protections / Diagnostics / Alarms	Over/Under voltage, Short circuit Overheating, Break phase			
Mechanical Specifications					
FDh	Height	100.4			mm
FDI	Depth	119.0			mm
FDw	Width	17.5			mm
FDnw	Weight	160			g
Rated range of use					
FCa	Altitude			2000	m
Idr	If current degrading every 1000m beyond the FCa altitude value		5		%
FCt	Temperature	0		50	°C
FCh	Humidity (no condensing)	5		90	%
Conditions of storage and transport					
SCa	Altitude			4000	m
SCt	Temperature	-20		70	°C
SCh	Humidity (no condensing)	5		95	%

DS1048A					
Symbol	Description	Value			Unit
		Min	Typ	Max	
Vac	Power supply AC voltage	18		36	Vac
If	Motor phase current (rms)	3		8	Arms
Vir	Automatic current reduction	0		100	%
Tir	Current reduction intervention time	0.05		10	s
Vacbrk	Permanent breakdown voltage			42	Vac
Vach	Over voltage protection intervention	40		42	Vac
Vacl	Under voltage protection intervention	14		15.6	Vac
Tchh	Thermal protection intervention threshold	85	90	95	°C
Tchl	Thermal protection restoration threshold	60	65	70	°C
Plss	Power lost on the drive			21	W
Res	Step resolution available	200, 400, 800, 1000, 1600, 2000, 3200, 4000, 5000, 6400, 10000, 12800, 25000, 25600			Step / Rev.
MI	Motor inductance seen by the drive	0.5		30	mH
Vdi	Digital input voltage range	3		28	Vdc
Vdibrk	Digital input breakdown voltage	-30		+30	Vdc
Idi	Digital input supply current	4	6	8	mA
Vdo	Digital output voltage range	1		30	Vdc
Vdobrk	Digital output breakdown voltage	-0.5		37	Vdc
Vdoz	Output zener diode voltage	37	39	42	Vdc
Ido	Digital output current range			50	mA
Idobrk	Digital output breakdown current	120			mA
Pwdo	Digital output dissipable power			300	mW
Fch	Chopper frequency		20		KHz
Prt	Protections / Diagnostics / Alarms	Over/Under voltage, Short circuit Overheating, Break phase			
Mechanical Specifications					
FDh	Height			100.4	mm
FDI	Depth			119.0	mm
FDw	Width			35	mm
FDnw	Weight			330	g
Rated range of use					
FCa	Altitude			2000	m
Idr	If current degrading every 1000m beyond the FCa altitude value		5		%
FCt	Temperature	0		50	°C
FCh	Humidity (no condensing)	5		90	%
Conditions of storage and transport					
SCa	Altitude			4000	m
SCt	Temperature	-20		70	°C
SCh	Humidity (no condensing)	5		95	%

DS1048					
Symbol	Description	Value			Unit
		Min	Typ	Max	
Vp	Power supply DC voltage	20		50	Vdc
If	Motor phase current (rms)	3		8	Arms
Vir	Automatic current reduction	0		100	%
Tir	Current reduction intervention time	0.05		10	s
Vprp	Allowed ripple (100Hz)			8	Vpp
Vpbrk	Permanent breakdown voltage	-0.5		60	Vdc
Vph	Over voltage protection intervention	56.0		57.6	Vdc
Vpl	Under voltage protection intervention	18.5		19.7	Vdc
Tchh	Thermal protection intervention threshold	85	90	95	°C
Tchl	Thermal protection restoration threshold	60	65	70	°C
Plss	Power lost on the drive			15	W
Res	Step resolution available	200, 400, 800, 1000, 1600, 2000, 3200, 4000, 5000, 6400, 10000, 12800, 25000, 25600			Step / Rev.
MI	Motor inductance seen by the drive	0.5		30	mH
Vdi	Digital input voltage range	3		28	Vdc
Vdibrk	Digital input breakdown voltage	-30		+30	Vdc
Idi	Digital input supply current	4	6	8	mA
Vdo	Digital output voltage range	1		30	Vdc
Vdobrk	Digital output breakdown voltage	-0.5		37	Vdc
Vdoz	Output zener diode voltage	37	39	42	Vdc
Ido	Digital output current range			60	mA
Idobrk	Digital output breakdown current	120			mA
Pwdo	Digital output dissipable power			300	mW
Fch	Chopper frequency		20		KHz
Prt	Protections / Diagnostics / Alarms	Over/Under voltage, Short circuit Overheating, Break phase			
Mechanical Specifications					
FDh	Height			100.4	mm
FDI	Depth			119.0	mm
FDw	Width			35	mm
FDnw	Weight			270	g
Rated range of use					
FCa	Altitude			2000	m
Idr	If current degrading every 1000m beyond the FCa altitude value		5		%
FCt	Temperature	0		50	°C
FCh	Humidity (no condensing)	5		90	%
Conditions of storage and transport					
SCa	Altitude			4000	m
SCt	Temperature	-20		70	°C
SCh	Humidity (no condensing)	5		95	%

DS1073A					
Symbol	Description	Value			Unit
		Min	Typ	Max	
Vac	Power supply AC voltage	20		65	Vac
If	Motor phase current (rms)	0.8		3	Arms
Vir	Automatic current reduction	0		100	%
Tir	Current reduction intervention time	0.05		10	s
Vacbrk	Permanent breakdown voltage			75	Vac
Vach	Over voltage protection intervention	69		73	Vac
Vacl	Under voltage protection intervention	16		18.6	Vac
Tchh	Thermal protection intervention threshold	85	90	95	°C
Tchl	Thermal protection restoration threshold	60	65	70	°C
Plss	Power lost on the drive			10	W
Res	Step resolution available	200, 400, 800, 1000, 1600, 2000, 3200, 4000, 5000, 6400, 10000, 12800, 25000, 25600			Step / Rev.
MI	Motor inductance seen by the drive	0.8		50	mH
Vdi	Digital input voltage range	3		28	Vdc
Vdibrk	Digital input breakdown voltage	-30		+30	Vdc
Idi	Digital input supply current	4	6	8	mA
Vdo	Digital output voltage range	1		30	Vdc
Vdobrk	Digital output breakdown voltage	-0.5		37	Vdc
Vdoz	Output zener diode voltage	37	39	42	Vdc
Ido	Digital output current range			60	mA
Idobrk	Digital output breakdown current	120			mA
Pwdo	Digital output dissipable power			300	mW
Fch	Chopper frequency		20		KHz
Prt	Protections / Diagnostics / Alarms	Over/Under voltage, Short circuit Overheating, Break phase			
Mechanical Specifications					
FDh	Height	100.4			mm
FDI	Depth	119.0			mm
FDw	Width	35.0			mm
FDnw	Weight	190			g
Rated range of use					
FCa	Altitude			2000	m
Idr	<i>If</i> current degrading every 1000m beyond the <i>FCa</i> altitude value		5		%
FCt	Temperature	0		50	°C
FCh	Humidity (no condensing)	5		90	%
Conditions of storage and transport					
SCa	Altitude			4000	m
SCt	Temperature	-20		70	°C
SCh	Humidity (no condensing)	5		95	%

DS1073					
Symbol	Description	Value			Unit
		Min	Typ	Max	
Vp	Power supply DC voltage	24		90	Vdc
If	Motor phase current (rms)	0.8		3	Arms
Vir	Automatic current reduction	0		100	%
Tir	Current reduction intervention time	0.05		10	s
Vprp	Allowed ripple (100Hz)			15	Vpp
Vpbrk	Permanent breakdown voltage	-0.5		105	Vdc
Vph	Over voltage protection intervention	95		98	Vdc
Vpl	Under voltage protection intervention	22.5		23.5	Vdc
Tchh	Thermal protection intervention threshold	85	90	95	°C
Tchl	Thermal protection restoration threshold	60	65	70	°C
Plss	Power lost on the drive			8	W
Res	Step resolution available	200, 400, 800, 1000, 1600, 2000, 3200, 4000, 5000, 6400, 10000, 12800, 25000, 25600			Step / Rev.
MI	Motor inductance seen by the drive	0.8		50	mH
Vdi	Digital input voltage range	3		28	Vdc
Vdibrk	Digital input breakdown voltage	-30		+30	Vdc
Idi	Digital input supply current	4	6	8	mA
Vdo	Digital output voltage range	1		30	Vdc
Vdobrk	Digital output breakdown voltage	-0.5		37	Vdc
Vdoz	Output zener diode voltage	37	39	42	Vdc
Ido	Digital output current range			60	mA
Idobrk	Digital output breakdown current	120			mA
Pwdo	Digital output dissipable power			300	mW
Fch	Chopper frequency		20		KHz
Prt	Protections / Diagnostics / Alarms	Over/Under voltage, Short circuit Overheating, Break phase			
Mechanical Specifications					
FDh	Height			100.4	mm
FDI	Depth			119.0	mm
FDw	Width			17.5	mm
FDnw	Weight			160	G
Rated range of use					
FCa	Altitude			2000	m
Idr	If current degrading every 1000m beyond the FCa altitude value		5		%
FCt	Temperature	0		50	°C
FCh	Humidity (no condensing)	5		90	%
Conditions of storage and transport					
SCa	Altitude			4000	m
SCT	Temperature	-20		70	°C
SCh	Humidity (no condensing)	5		95	%

DS1076A					
Symbol	Description	Value			Unit
		Min	Typ	Max	
Vac	Power supply AC voltage	20		65	Vac
If	Motor phase current (rms)	2		6	Arms
Vir	Automatic current reduction	0		100	%
Tir	Current reduction intervention time	0.05		10	S
Vacbrk	Permanent breakdown voltage			75	Vac
Vach	Over voltage protection intervention	69		73	Vac
Vacl	Under voltage protection intervention	16		18.6	Vac
Tchh	Thermal protection intervention threshold	85	90	95	°C
Tchl	Thermal protection restoration threshold	60	65	70	°C
Plss	Power lost on the drive			20	W
Res	Step resolution available	200, 400, 800, 1000, 1600, 2000, 3200, 4000, 5000, 6400, 10000, 12800, 25000, 25600			Step / Rev.
MI	Motor inductance seen by the drive	0.6		40	mH
Vdi	Digital input voltage range	3		28	Vdc
Vdibrk	Digital input breakdown voltage	-30		+30	Vdc
Idi	Digital input supply current	4	6	8	mA
Vdo	Digital output voltage range	1		30	Vdc
Vdobrk	Digital output breakdown voltage	-0.5		37	Vdc
Vdoz	Output zener diode voltage	37	39	42	Vdc
Ido	Digital output current range			50	mA
Idobrk	Digital output breakdown current	120			mA
Pwdo	Digital output dissipable power			300	mW
Fch	Chopper frequency		20		KHz
Prt	Protections / Diagnostics / Alarms	Over/Under voltage, Short circuit Overheating, Break phase			
Mechanical Specifications					
FDh	Height			100.4	mm
FDI	Depth			119.0	mm
FDw	Width			35	mm
FDnw	Weight			330	g
Rated range of use					
FCa	Altitude			2000	m
Idr	<i>If</i> current degrading every 1000m beyond the <i>FCa</i> altitude value		5		%
FCt	Temperature	0		50	°C
FCh	Humidity (no condensing)	5		90	%
Conditions of storage and transport					
SCa	Altitude			4000	m
SCt	Temperature	-20		70	°C
SCh	Humidity (no condensing)	5		95	%

DS1076					
Symbol	Description	Value			Unit
		Min	Typ	Max	
Vp	Power supply DC voltage	24		90	Vdc
If	Motor phase current (rms)	2		6	Arms
Vir	Automatic current reduction	0		100	%
Tir	Current reduction intervention time	0,05		10	s
Vprp	Allowed ripple (100Hz)			15	Vpp
Vpbrk	Permanent breakdown voltage	-0.5		105	Vdc
Vph	Over voltage protection intervention	95		98	Vdc
Vpl	Under voltage protection intervention	22.5		23.5	Vdc
Tchh	Thermal protection intervention threshold	85	90	95	°C
Tchl	Thermal protection restoration threshold	60	65	70	°C
Plss	Power lost on the drive			15	W
Res	Step resolution available	200, 400, 800, 1000, 1600, 2000, 3200, 4000, 5000, 6400, 10000, 12800, 25000, 25600			Step / Rev.
MI	Motor inductance seen by the drive	0.6		40	mH
Vdi	Digital input voltage range	3		28	Vdc
Vdibrk	Digital input breakdown voltage	-30		+30	Vdc
Idi	Digital input supply current	4	6	8	mA
Vdo	Digital output voltage range	1		30	Vdc
Vdobrk	Digital output breakdown voltage	-0.5		37	Vdc
Vdoz	Output zener diode voltage	37	39	42	Vdc
Ido	Digital output current range			60	mA
Idobrk	Digital output breakdown current	120			mA
Pwdo	Digital output dissipable power			300	mW
Fch	Chopper frequency		20		KHz
Prt	Protections / Diagnostics / Alarms	Over/Under voltage, Short circuit Overheating, Break phase			
Mechanical Specifications					
FDh	Height	100.4			mm
FDI	Depth	119.0			mm
FDw	Width	35			mm
FDnw	Weight	270			g
Rated range of use					
FCa	Altitude			2000	m
Idr	If current degrading every 1000m beyond the FCa altitude value		5		%
FCt	Temperature	0		50	°C
FCh	Humidity (no condensing)	5		90	%
Conditions of storage and transport					
SCa	Altitude			4000	m
SCt	Temperature	-20		70	°C
SCh	Humidity (no condensing)	5		95	%

DS1078A					
Symbol	Description	Value			Unit
		Min	Typ	Max	
Vac	Power supply AC voltage	20		65	Vac
If	Motor phase current (rms)	4		10	Arms
Vir	Automatic current reduction	0		100	%
Tir	Current reduction intervention time	0.05		10	s
Vacbrk	Permanent breakdown voltage			75	Vac
Vach	Over voltage protection intervention	69		73	Vac
Vacl	Under voltage protection intervention	16		18.6	Vac
Tchh	Thermal protection intervention threshold	85	90	95	°C
Tchl	Thermal protection restoration threshold	60	65	70	°C
Plss	Power lost on the drive			24	W
Res	Step resolution available	200, 400, 800, 1000, 1600, 2000, 3200, 4000, 5000, 6400, 10000, 12800, 25000, 25600			Step / Rev.
MI	Motor inductance seen by the drive	0.5		30	mH
Vdi	Digital input voltage range	3		28	Vdc
Vdibrk	Digital input breakdown voltage	-30		+30	Vdc
Idi	Digital input supply current	4	6	8	mA
Vdo	Digital output voltage range	1		30	Vdc
Vdobrk	Digital output breakdown voltage	-0.5		37	Vdc
Vdoz	Output zener diode voltage	37	39	42	Vdc
Ido	Digital output current range			60	mA
Idobrk	Digital output breakdown current	120			mA
Pwdo	Digital output dissipable power			300	mW
Fch	Chopper frequency		20		KHz
Prt	Protections / Diagnostics / Alarms	Over/Under voltage, Short circuit Overheating, Break phase			
Mechanical Specifications					
FDh	Height			100.4	mm
FDI	Depth			119.0	mm
FDw	Width			35	mm
FDnw	Weight			330	g
Rated range of use					
FCa	Altitude			2000	m
Idr	<i>If</i> current degrading every 1000m beyond the <i>FCa</i> altitude value		5		%
FCt	Temperature	0		50	°C
FCh	Humidity (no condensing)	5		90	%
Conditions of storage and transport					
SCa	Altitude			4000	m
SCt	Temperature	-20		70	°C
SCh	Humidity (no condensing)	5		95	%

DS1078					
Symbol	Description	Value			Unit
		Min	Typ	Max	
Vp	Power supply DC voltage	24		90	Vdc
If	Motor phase current (rms)	4		10	Arms
Vir	Automatic current reduction	0		100	%
Tir	Current reduction intervention time	0.05		10	s
Vprp	Allowed ripple (100Hz)			15	Vpp
Vpbrk	Permanent breakdown voltage	-0.5		105	Vdc
Vph	Over voltage protection intervention	95		98	Vdc
Vpl	Under voltage protection intervention	22.5		23.5	Vdc
Tchh	Thermal protection intervention threshold	85	90	95	°C
Tchl	Thermal protection restoration threshold	60	65	70	°C
Plss	Power lost on the drive			15	W
Res	Step resolution available	200, 400, 800, 1000, 1600, 2000, 3200, 4000, 5000, 6400, 10000, 12800, 25000, 25600			Step / Rev.
MI	Motor inductance seen by the drive	0.5		30	mH
Vdi	Digital input voltage range	3		28	Vdc
Vdibrk	Digital input breakdown voltage	-30		+30	Vdc
Idi	Digital input supply current	4	6	8	mA
Vdo	Digital output voltage range	1		30	Vdc
Vdobrk	Digital output breakdown voltage	-0.5		37	Vdc
Vdoz	Output zener diode voltage	37	39	42	Vdc
Ido	Digital output current range			60	mA
Idobrk	Digital output breakdown current	120			mA
Pwdo	Digital output dissipable power			300	mW
Fch	Chopper frequency		20		KHz
Prt	Protections / Diagnostics / Alarms	Over/Under voltage, Short circuit Overheating, Break phase			
Mechanical Specifications					
FDh	Height	100.4			mm
FDI	Depth	119.0			mm
FDw	Width	35			mm
FDnw	Weight	270			g
Rated range of use					
FCa	Altitude			2000	m
Idr	If current degrading every 1000m beyond the FCa altitude value		5		%
FCt	Temperature	0		50	°C
FCh	Humidity (no condensing)	5		90	%
Conditions of storage and transport					
SCa	Altitude			4000	m
SCt	Temperature	-20		70	°C
SCh	Humidity (no condensing)	5		95	%

DS1084A					
Symbol	Description	Value			Unit
		Min	Typ	Max	
Vac	Power supply AC voltage	35		115	Vac
If	Motor phase current (rms)	2		4	Arms
Vir	Automatic current reduction	0		100	%
Tir	Current reduction intervention time	0.05		10	s
Vacbrk	Permanent breakdown voltage			142	Vac
Vach	Over voltage protection intervention	120		126	Vac
Vacl	Under voltage protection intervention	31		33.6	Vac
Tchh	Thermal protection intervention threshold	85	90	95	°C
Tchl	Thermal protection restoration threshold	60	65	70	°C
Plss	Power lost on the drive			20	W
Res	Step resolution available	200, 400, 800, 1000, 1600, 2000, 3200, 4000, 5000, 6400, 10000, 12800, 25000, 25600			Step / Rev.
MI	Motor inductance seen by the drive	1		50	mH
Vdi	Digital input voltage range	3		28	Vdc
Vdibrk	Digital input breakdown voltage	-30		+30	Vdc
Idi	Digital input supply current	4	6	8	mA
Vdo	Digital output voltage range	1		30	Vdc
Vdobrk	Digital output breakdown voltage	-0.5		37	Vdc
Vdoz	Output zener diode voltage	37	39	42	Vdc
Ido	Digital output current range			60	mA
Idobrk	Digital output breakdown current	120			mA
Pwdo	Digital output dissipable power			300	mW
Fch	Chopper frequency		20		KHz
Prt	Protections / Diagnostics / Alarms	Over/Under voltage, Short circuit Overheating, Break phase			
Mechanical Specifications					
FDh	Height			100.4	mm
FDI	Depth			119.0	mm
FDw	Width			35	mm
FDnw	Weight			330	g
Rated range of use					
FCa	Altitude			2000	m
Idr	<i>If</i> current degrading every 1000m beyond the <i>FCa</i> altitude value		5		%
FCt	Temperature	0		50	°C
FCh	Humidity (no condensing)	5		90	%
Conditions of storage and transport					
SCa	Altitude			4000	m
SCt	Temperature	-20		70	°C
SCh	Humidity (no condensing)	5		95	%

DS1084					
Symbol	Description	Value			Unit
		Min	Typ	Max	
Vp	Power supply DC voltage	45		160	Vdc
If	Motor phase current (rms)	2		4	Arms
Vir	Automatic current reduction	0		100	%
Tir	Current reduction intervention time	0.05		10	s
Vprp	Allowed ripple (100Hz)			25	Vpp
Vpbrk	Permanent breakdown voltage	-0.5		210	Vdc
Vph	Over voltage protection intervention	177		181	Vdc
Vpl	Under voltage protection intervention	26		27	Vdc
Tchh	Thermal protection intervention threshold	85	90	95	°C
Tchl	Thermal protection restoration threshold	60	65	70	°C
Plss	Power lost on the drive			15	W
Res	Step resolution available	200, 400, 800, 1000, 1600, 2000, 3200, 4000, 5000, 6400, 10000, 12800, 25000, 25600			Step / Rev.
MI	Motor inductance seen by the drive	1		50	mH
Vdi	Digital input voltage range	3		28	Vdc
Vdibrk	Digital input breakdown voltage	-30		+30	Vdc
Idi	Digital input supply current	4	6	8	mA
Vdo	Digital output voltage range	1		30	Vdc
Vdobrk	Digital output breakdown voltage	-0.5		37	Vdc
Vdoz	Output zener diode voltage	37	39	42	Vdc
Ido	Digital output current range			60	mA
Idobrk	Digital output breakdown current	120			mA
Pwdo	Digital output dissipable power			300	mW
Fch	Chopper frequency		20		KHz
Prt	Protections / Diagnostics / Alarms	Over/Under voltage, Short circuit Overheating, Break phase			
Mechanical Specifications					
FDh	Height	100.4			mm
FDI	Depth	119.0			mm
FDw	Width	35			mm
FDnw	Weight	270			g
Rated range of use					
FCa	Altitude			2000	m
Idr	If current degrading every 1000m beyond the FCa altitude value		5		%
FCt	Temperature	0		50	°C
FCh	Humidity (no condensing)	5		90	%
Conditions of storage and transport					
SCa	Altitude			4000	m
SCT	Temperature	-20		70	°C
SCh	Humidity (no condensing)	5		95	%

DS1087A					
Symbol	Description	Value			Unit
		Min	Typ	Max	
Vac	Power supply AC voltage	35		115	Vac
If	Motor phase current (rms)	4		8.5	Arms
Vir	Automatic current reduction	0		100	%
Tir	Current reduction intervention time	0.05		10	s
Vacbrk	Permanent breakdown voltage			142	Vac
Vach	Over voltage protection intervention	120		126	Vac
Vacl	Under voltage protection intervention	31		33.6	Vac
Tchh	Thermal protection intervention threshold	85	90	95	°C
Tchl	Thermal protection restoration threshold	60	65	70	°C
Plss	Power lost on the drive			36	W
Res	Step resolution available	200, 400, 800, 1000, 1600, 2000, 3200, 4000, 5000, 6400, 10000, 12800, 25000, 25600			Step / Rev.
MI	Motor inductance seen by the drive	0.6		35	mH
Vdi	Digital input voltage range	3		28	Vdc
Vdibrk	Digital input breakdown voltage	-30		+30	Vdc
Idi	Digital input supply current	4	6	8	mA
Vdo	Digital output voltage range	1		30	Vdc
Vdobrk	Digital output breakdown voltage	-0.5		37	Vdc
Vdoz	Output zener diode voltage	37	39	42	Vdc
Ido	Digital output current range			60	mA
Idobrk	Digital output breakdown current	120			mA
Pwdo	Digital output dissipable power			300	mW
Fch	Chopper frequency		20		KHz
Prt	Protections / Diagnostics / Alarms	Over/Under voltage, Short circuit Overheating, Break phase			
Mechanical Specifications					
FDh	Height			100.4	mm
FDI	Depth			119.0	mm
FDw	Width			35	mm
FDnw	Weight			330	g
Rated range of use					
FCa	Altitude			2000	m
Idr	<i>If</i> current degrading every 1000m beyond the <i>FCa</i> altitude value		5		%
FCt	Temperature	0		50	°C
FCh	Humidity (no condensing)	5		90	%
Conditions of storage and transport					
SCa	Altitude			4000	m
SCt	Temperature	-20		70	°C
SCh	Humidity (no condensing)	5		95	%

DS1087					
Symbol	Description	Value			Unit
		Min	Typ	Max	
Vp	Power supply DC voltage	45		160	Vdc
If	Motor phase current (rms)	4		8.5	Arms
Vir	Automatic current reduction	0		100	%
Tir	Current reduction intervention time	0.05		10	s
Vprp	Allowed ripple (100Hz)			25	Vpp
Vpbrk	Permanent breakdown voltage	-0,5		210	Vdc
Vph	Over voltage protection intervention	177		181	Vdc
Vpl	Under voltage protection intervention	26		27	Vdc
Tchh	Thermal protection intervention threshold	85	90	95	°C
Tchl	Thermal protection restoration threshold	60	65	70	°C
Plss	Power lost on the drive			20	W
Res	Step resolution available	200, 400, 800, 1000, 1600, 2000, 3200, 4000, 5000, 6400, 10000, 12800, 25000, 25600			Step / Rev.
MI	Motor inductance seen by the drive	0.6		35	mH
Vdi	Digital input voltage range	3		28	Vdc
Vdibrk	Digital input breakdown voltage	-30		+30	Vdc
Idi	Digital input supply current	4	6	8	mA
Vdo	Digital output voltage range	1		30	Vdc
Vdobrk	Digital output breakdown voltage	-0.5		37	Vdc
Vdoz	Output zener diode voltage	37	39	42	Vdc
Ido	Digital output current range			60	mA
Idobrk	Digital output breakdown current	120			mA
Pwdo	Digital output dissipable power			300	mW
Fch	Chopper frequency		20		KHz
Prt	Protections / Diagnostics / Alarms	Over/Under voltage, Short circuit Overheating, Break phase			
Mechanical Specifications					
FDh	Height	100.4			mm
FDI	Depth	119.0			mm
FDw	Width	35			mm
FDnw	Weight	270			g
Rated range of use					
FCa	Altitude			2000	m
Idr	<i>If current degrading every 1000m beyond the FCa altitude value</i>		5		%
FCt	Temperature	0		50	°C
FCh	Humidity (no condensing)	5		90	%
Conditions of storage and transport					
SCa	Altitude			4000	m
SCt	Temperature	-20		70	°C
SCh	Humidity (no condensing)	5		95	%

DS1098					
Symbol	Description	Value			Unit
		Min	Typ		
Vp	Power supply DC voltage	45		240	Vdc
If	Motor phase current (rms)	4		10	Arms
Vir	Automatic current reduction	0		100	%
Tir	Current reduction intervention time	0.05		10	s
Vprp	Allowed ripple (100Hz)			30	Vpp
Vpbrk	Permanent breakdown voltage	-0.5		265	Vdc
Vph	Over voltage protection intervention	242		255	Vdc
Vpl	Under voltage protection intervention	35		37	Vdc
Tchh	Thermal protection intervention threshold	85	90	95	°C
Tchl	Thermal protection restoration threshold	60	65	70	°C
Plss	Power lost on the drive			30	W
Res	Step resolution available	200, 400, 800, 1000, 1600, 2000, 3200, 4000, 5000, 6400, 10000, 12800, 25000, 25600			Step / Rev.
MI	Motor inductance seen by the drive	0.6		30	mH
Vdi	Digital input voltage range	3		28	Vdc
Vdibrk	Digital input breakdown voltage	-30		+30	Vdc
Idi	Digital input supply current	4	6	8	mA
Vdo	Digital output voltage range	1		30	Vdc
Vdobrk	Digital output breakdown voltage	-0.5		37	Vdc
Vdoz	Output zener diode voltage	37	39	42	Vdc
Ido	Digital output current range			60	mA
Idobrk	Digital output breakdown current	120			mA
Pwdo	Digital output dissipable power			300	mW
Fch	Chopper frequency		20		KHz
Prt	Protections / Diagnostics / Alarms	Over/Under voltage, Short circuit Overheating, Break phase			
Mechanical Specifications					
FDh	Height			100.4	mm
FDI	Depth			119.0	mm
FDw	Width			35	mm
FDnw	Weight			270	g
Rated range of use					
FCa	Altitude			2000	m
Idr	If current degrading every 1000m beyond the FCa altitude value		5		%
FCt	Temperature	0		50	°C
FCh	Humidity (no condensing)	5		90	%
Conditions of storage and transport					
SCa	Altitude			4000	m
SCt	Temperature	-20		70	°C
SCh	Humidity (no condensing)	5		95	%

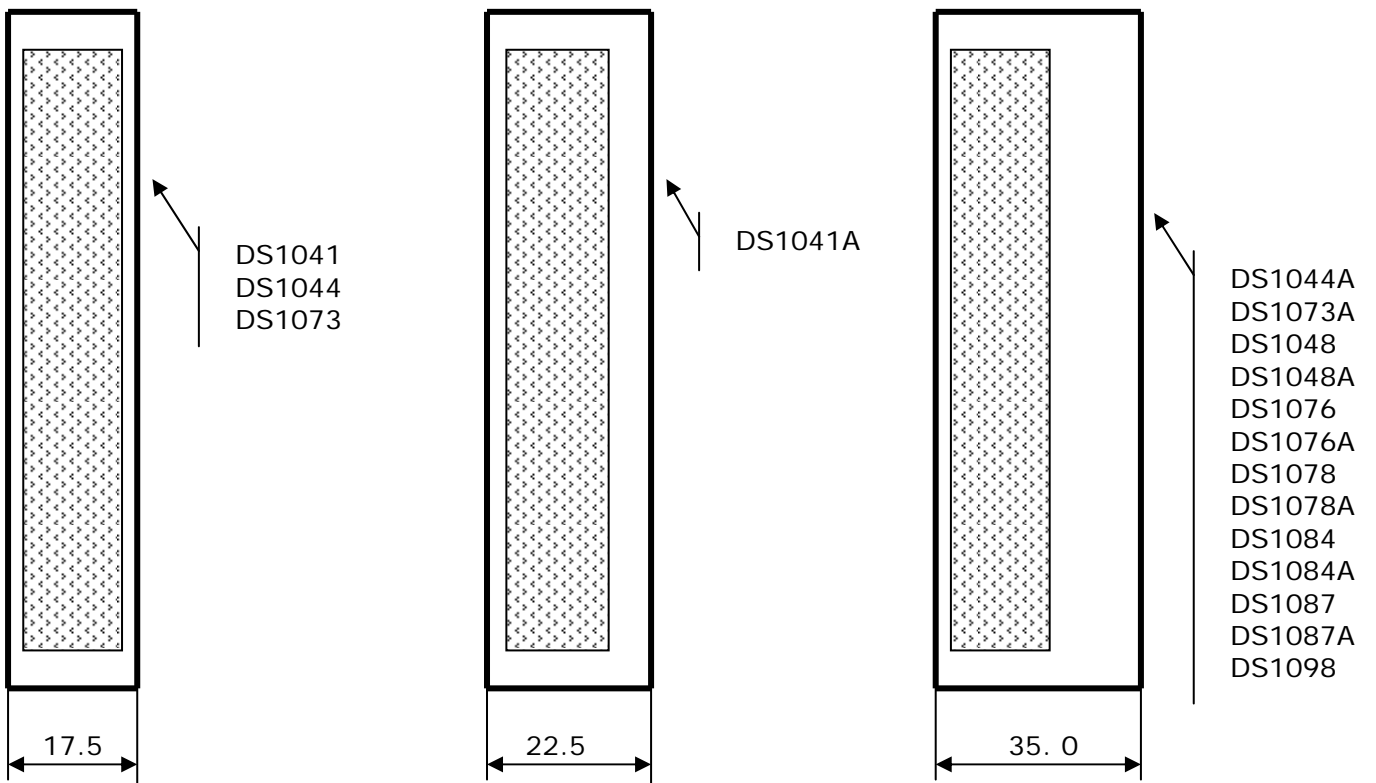
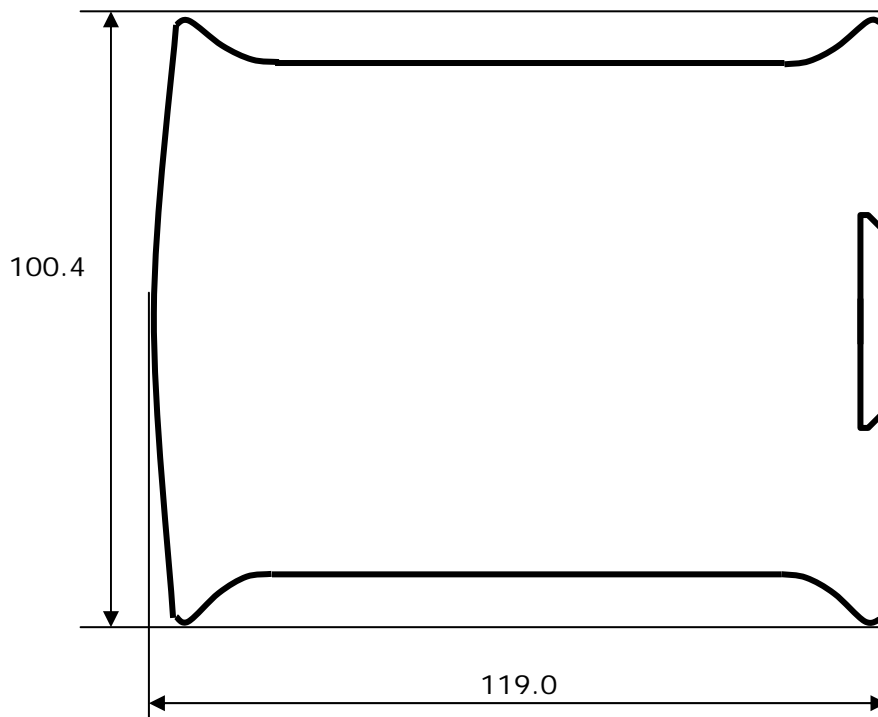

Dimensions expressed in millimeters. Non-full scale drawings.



LAM Technologies
Viale Ludovico Ariosto, 492/D
50019 Sesto Fiorentino
Firenze - ITALY

Ph. +39 055 4207746
Fax +39 055 4207651

www.lamtechnologies.com

General information info@lamtechnologies.com
Technical support support@lamtechnologies.com
Sales information sales@lamtechnologies.com