



2,4A 42Vdc Microstepping Driver

- Resolution selection up to 1/128 step mode
- Change resolution “on the fly”
- Logic signal TTL/CMOS compatible
- Current up to 2.4A per phase
- Chopper frequency over 22KHz
- Wide power supply range (12-42V)
- Full short circuit protection
- Automatic current reduction
- Open collector FAULT output
- ENABLE input
- Internal pull-up on all inputs
- Compact size
- Easy to use
- Cost effective



High performance and cost effective USD10362 drive module has been designed to drive permanent bipolar stepping motors with phase current between 0.3A and 2.4A. This drive module allows the control of the microstepping motor rotation so to exploit the possibility given by stepping motors of carrying out open loop repetitive positioning and solving those resonance and resolution problems which up to now have made impossible to use stepping motors for certain applications. Step resolution can be changed “on the fly”, i.e. during motor rotation, without causing any irregularity to its operation. The speed range is consequently wider (from 0 to 6000rpm with 200 steps for revolution motor).

A bipolar MOSFET chopper current control guarantees high efficiency and low losses. Special circuits grant efficient current control even during critical situation as, for example, crossing of the motor resonance’s points or during the braking when the motor acts like a generator.

The current ripple in the windings is kept at very low values to reduce the heat of the motor.

Automatic current reduction, selectable on values of 25% or 50% of rated current, minimizes heat losses when the motor is at rest.

Full short circuit protection (phase to phase, phase to ground and phase to supply) makes USD10362 very rugged.

The FAULT output can be used for diagnostic purposes as it reveals malfunctions such as phase short circuits or supply lower to the recommended one. The fault output is an open collector configuration, so it is possible to connect multiple FAULT outputs together in multi axis applications.

Internal pull-up resistors on each input of USD10362 drive module allow easy connectivity.



Operating parameters (@ Ta = 25°C)

Symbol	Parameter	Test	Value			Unit
			Min	Typ	Max	
Vp	Power supply		12	36	42	V
Vcc	Logic power supply		4.75	5	5.25	V
In	Rated current		0.3		2.4	A
Istandby	Current reduction		25		50	% out of In
Res	Resolution selection		from full step to 1/128			Step fract.
Is	Quiescent current	ENABLE = low			40	mA
Icc	Logic current	All inputs low			100	mA
Iil	Low input current	Vi = low			500	uA
Iih	High input current	Vi = high			10	uA
Vil	Max low level for input				0.8	V
Vih	Min high level for input		2			V
Fc	Chopper frequency	Vcc = 5V	18	22	27	KHz
Imax	Current protection trigger	Vp = 36V			5	A
Ifault	FAULT output current				200	mA
Vfon	Output voltage with FAULT on	Ifault = 100mA			0.4	V
Vfoff	Maximum voltage applicable to FAULT output				38	V
fstep	STEPIN frequency	Vcc = 5V			20	KHz
tlstep	STEPIN low level time	Vcc = 5V	1			usec
treset	Delay after RESET	Vcc = 5V	500			usec
tlreset	Min RESET pulse	Vcc = 5V	1			usec
tset	Set up time	Vcc = 5V	0			usec
thold	Hold time	Vcc = 5V	40			usec
tenable	Delay after ENABLE		0			usec
tstandby	Current reduction operating time			80		msec
tfault	FAULT signal duration	Vcc = 5V Vp = 36V		200		msec
Tvpon	Activation time after Vp>12V	Vcc = 5V Vp = 36V		200		msec



Absolute maximum range

Symbol	Parameter	Value	Unit
Vp	Power supply voltage	-0.5 / 48	V
Vcc	Logic supply voltage	-0.5 / 6	V
Vin	Input voltage (for all inputs)	-0.5 / 6	V
Vfault	Voltage applied to FAULT input	-0.5 / 48	V
Ifault	Current delivered by FAULT input	300	mA
Tcop	Case operating temperature	0 – 70	°C

Signals timing

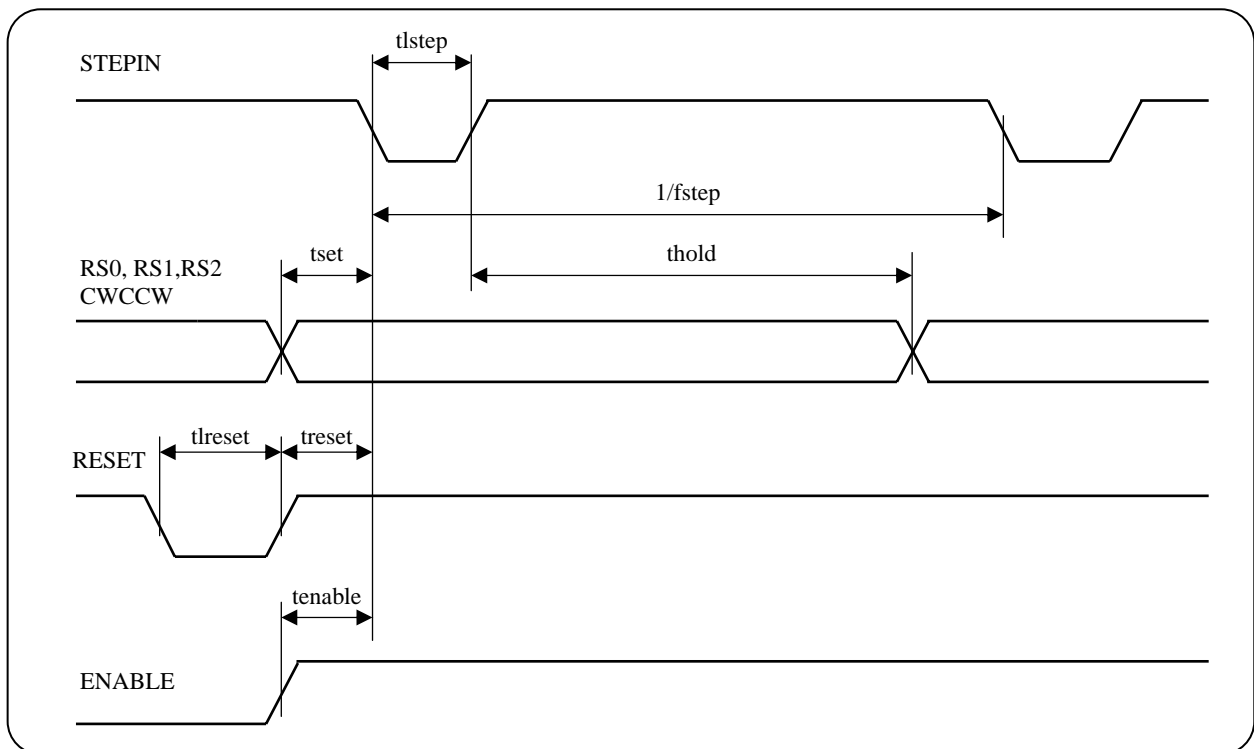

Pin out connections

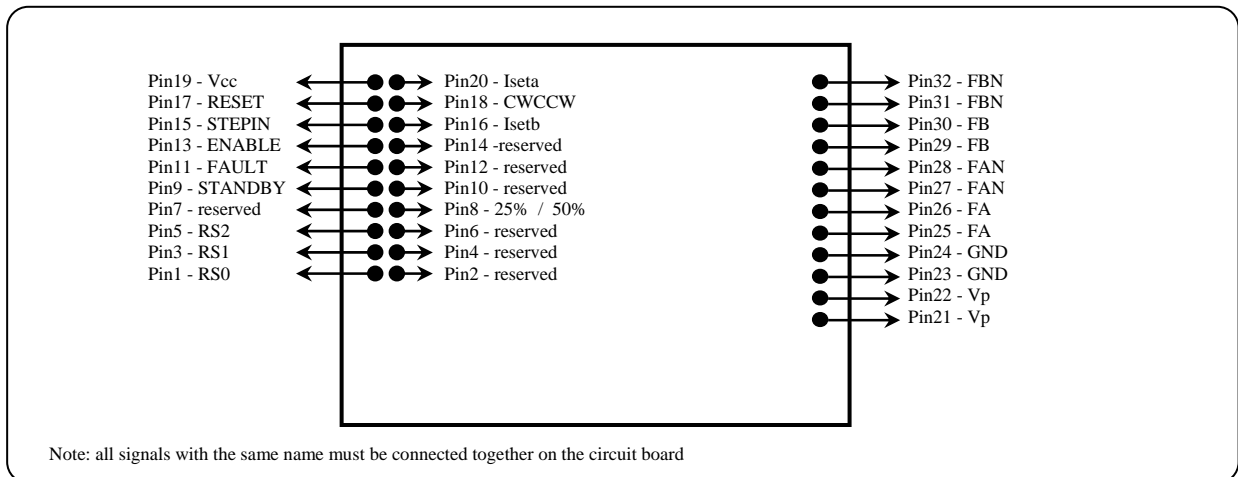



Signals description

<i>Pin</i>	<i>Name</i>	<i>Description</i>
1	RS0	Step resolution selection input. These inputs can be changed also during motor rotation to change the step resolution “on the fly”.
3	RS1	
5	RS2	
8	25% / 50%	Input for current reduction percentage setting. If pin is left unconnected or connected to Vcc with motor at rest, current is reduced to 50% of rated value. While, if pin is connected to ground, with motor at rest, the current is reduced to 25% of the rated value.
9	STANDBY	Standby input. When kept low, the automatic current reduction is disabled.
11	FAULT	Open collector output. It is brought to low logic level when one of the short circuit protections is triggered.
13	ENABLE	Enable input. When kept low, power stage is disabled.
15	STEPIN	Step input. On high-low transition the motor moves of an angle depending on the setting of RS0, RS1 and RS2 signals.
16	Isetb	Input for phase current setting. The current delivered by drive module can be modified by connecting a resistor between these pins and GND.
20	Iseta	
17	RESET	Reset input.
18	CWCCW	Direction of motor rotation control input. Changing the logic level from low to high or vice versa, the direction of motor rotation is reversed.
19	Vcc	Logic supply input.
21, 22	Vp	Power supply input.
23, 24	GND	Ground for logic and power supply.
25, 26	FA	Power stage output to be connected to stepping motor phase A (+)
27, 28	FAN	Power stage output to be connected to stepping motor reversed phase A (-)
29, 30	FB	Power stage output to be connected to stepping motor phase B (+)
31, 32	FBN	Power stage output to be connected to stepping motor reversed phase B (-)
2, 4, 6, 7, 10, 12, 14	Reserved	Reserved pins. They must not be connected.



Voltage supply

Only two supply voltages are necessary to operate USD10362 drive module. One supplies the logic section, while the other delivers energy to the power stage. Even though it is possible for the voltage supplies to reach or leave the drive module in any sequence, it is better the Vcc supply reaches the drive module before Vp supply when turning the drive on and leaves the drive after Vp when turning it off.

If Vcc voltage rise time is higher than 200msec an external circuit is necessary to generate a reset pulse after Vcc has gone beyond min. level recommended.

A capacitive filter is placed inside the USD10362 drive between Vp and GND. Anyway when developing the printed circuit board it is necessary to provide for an external capacitor of at least 1000uF and of adequate voltage to be placed very near to 21/22 and 23/24 pins.

In case more drive modules are placed on the same printed circuit board, each drive must have its own capacitor at its side.

Phase current setting

The rated current for each phase can be set through two 1/4W resistors placed between pins 16/20 and GND. The value of the two resistors must be identical to avoid any unbalanced rotation in the stepping motor. The relationship between the value of each resistor and the output rated current is as follows:

$$I_n = \frac{4.8 \left(\frac{3300 R_x}{3300 + R_x} \right)}{0.5 \left(10000 + \frac{3300 R_x}{3300 + R_x} \right)}$$

Where Rx is the value to be used for both resistors.

The following table will provide you with the right resistor for the motor connected to the drive module

<i>R_x</i>	<i>I_n</i>
390 ohm	0.32A
1K	0.68A
1K8	1.00A
4K7	1.55A
15K	2A
>1M	2.4A

The layout of the printed circuit board has to be designed so that the connection between the resistors' terminals and the pins of the drive module is as short as possible. We also strongly recommend to connect resistors to GND directly on 23/24 pins.

Phase rated current setting can be changed even during motor rotation. For instance the motor can be boosted during acceleration and deceleration, i.e. when rotor and load inertia are added to frictions so that the max. value of the resisting torque is reached. Then, during constant rotation speed the current can be brought back to rated value.

Two analogue switches (for example 1/2 CD4066) are the only components necessary to carry out the above described current change. They make resistor Rx (corresponding to the motor boost current) be in parallel with a second one, so that the two parallel resistors correspond to the rated current value.



Resolution setting

By the RS0, RS1 and RS2 inputs it is possible to set the movement resolution.

Changing these signals the rotor's angle, executed on the falling edge of the STEPIN input, is modified.

The following table shows all the possible combinations allowed and for each one the corresponding step angle:

<i>RS2</i>	<i>RS1</i>	<i>RS0</i>	<i>Resolution</i>
0	0	0	Full step
0	0	1	1/2 full step
0	1	0	1/4 full step
0	1	1	1/8 full step
1	0	0	1/16 full step
1	0	1	1/32 full step
1	1	0	1/64 full step
1	1	1	1/128 full step

The special USD10362 internal logic allows to change the movement resolution also during motor rotation without lost of the motor position or need to reset the driver.

This special feature allows to always choose the best resolution for each speed range.

For example, a movement cycle can be started at 1/128 full step resolution and, during acceleration resolution will be decreased to 1/64 and then to 1/32 and so on to obtain high speed with low STEPIN frequency pulse applied. During deceleration the process will be reversed to stop the motor at the maximum resolution of 1/128 full step. The described algorithm is easily implementable on standard microcontroller.

RESET Signal

When active this inputs signal resets the internal logic circuit. This signal is often not used and the corresponding pin can be left disconnected. Only when the Vcc supply voltage rise time is more than 200msec, a RESET pulse must be externally generated, after Vcc voltage has reached min.

recommended value.

CWCCW Signal

This signal allows to reverse the direction of the motor rotation. It is not possible to define before the rotation direction as a function of the logic level assumed by the CWCCW signal, as the rotation direction depends on the connection sequence of the motor's phases.

STEPIN Signal

On the high-low transition of the signal applied to pin15 the motor executes a rotation step, in the direction specified through the CWCCW input, of an angle as defined by the logic level of RS0, RS1 and RS2 signals.

ENABLE Signal

The output stage is disabled when bringing this input to low logic level. The stepping motor torque and the current are consequently turned off. When the application does not require motor torque while at rest, this input can be used to reduce to minimum the heat losses in the motor and in the drive module.

STANDBY Signal

The automatic current reduction is disabled when this input is set to low logic level.

Otherwise, with pin9 left unconnected USD10361 reduces automatically the rated current of 25% or 50% (according to the logic level applied to pin8) about 80msec after the last STEPIN input pulse has been received. The rated current is set up again at the next pulse applied on the STEPIN input. Managing opportunely the STANDBY signal it is possible to delay the automatic current reduction time or to set up the full rated current.



25% / 50% Signal

This signal allows to change the current level when motor is at rest. Leaving pin8 unconnected or connecting it to Vcc the current is reduced to 50% of the rated value.

Connecting pin8 to ground the current is reduced to 25% of the rated value.

When the application does not require motor torque while at rest, it is better to set current reduction at 25% connecting pin8 to ground. This allows to reduce the heat losses in the motor and in the drive module.

FAULT Output

FAULT output starts up whenever a short circuit occurs between output phases (direct or crossed), or a phase is connected with GND or Vp, or Vp voltage is under 12V. The signal remains active as long as the fault occurs, plus about 200msec after the normal operating conditions have been restored. The special open collector configuration allows mutual connections between FAULT outputs of different drive modules, to then connect through an unique signal to the control logic. The current capacity of this output allows the driving of small relays. While connecting a relay it is necessary to parallel with the coil a diode, protecting the FAULT output from extra voltages caused by inductive loads.

Current reduction at $T_a > 25^\circ\text{C}$

When the external temperature is over 25°C , you must consider the following waveforms to determine the max. deliverable current by the driver, in absence of a fan cooler.

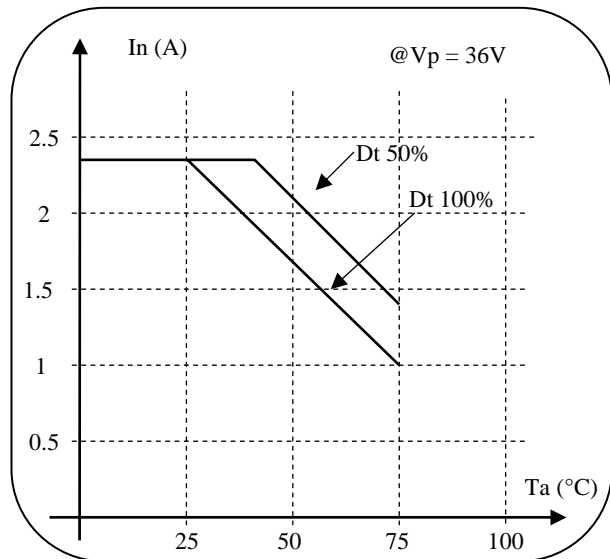

It is important to take note that if the working cycle is at 50%, the reachable current limit is much higher compared to a motor driver continuously working.

The case's temperature can be effectively reduced through an external fan cooler. In this case it is possible to take the max. current continuously according to the efficacy of the cooling system.



Mechanical dimensions

